

# Secomak

## 587 TURBO BLOWER



- High volume output
- Low running costs
- Excellent reliability
- Long life
- Low noise
- Virtually maintenance-free
- Compact



The **Secomak 587 Turbo Blower** has been specially developed to deliver maximum performance yet ensuring smooth air delivery across the whole of the performance curve. A conventional blower with a similar output to the 587 would be almost three times its physical size. Designed for continuous and virtually maintenance-free running, the Turbo Blower can operate in ambient temperatures up to 40°C.

Its simple belt arrangement and large impeller gives excellent reliability while its relatively low fan speed ensures longer life. All units come complete with a stainless steel enclosure to reduce noise levels to a minimum. An intake filter is available for clean air applications.

The Turbo Blower is the power behind the **Secomak POWERSTRIP System** designed for fast and efficient drying of bottles, cans and jars. The 587 has many other industrial uses, however, including pneumatic conveying, aeration and vacuum holding and lifting.

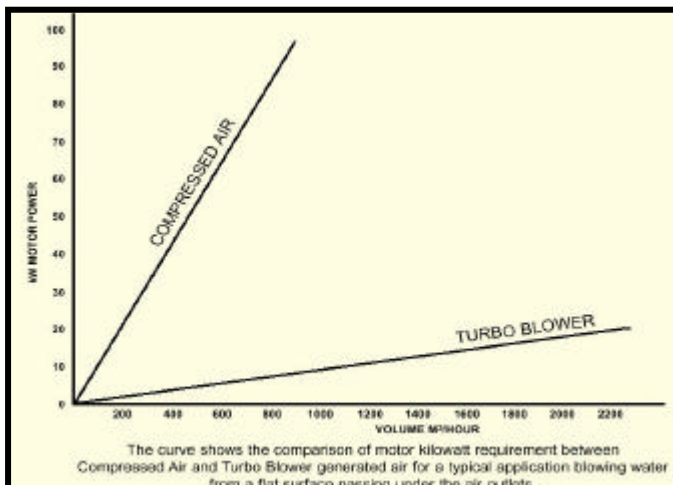

Due to the use of fan technology rather than using a compressor, the energy required to supply air is reduced significantly resulting in low running costs.



The power behind POWERSTRIP Drying Systems for fast drying of bottles, cans and jars is the 587 Turbo Blower.

### Secomak

Honeyplot Lane, Stanmore, Middlesex, HA7 1JR

Tel: +44 (0) 20 8952 5566

Fax: +44 (0) 20 8952 6983

E-mail: [sales@secomak.com](mailto:sales@secomak.com)

Web: [www.secomak.com](http://www.secomak.com)

A  
**HALMA**  
GROUP  
COMPANY

# Secomak

## 587 TURBO BLOWER

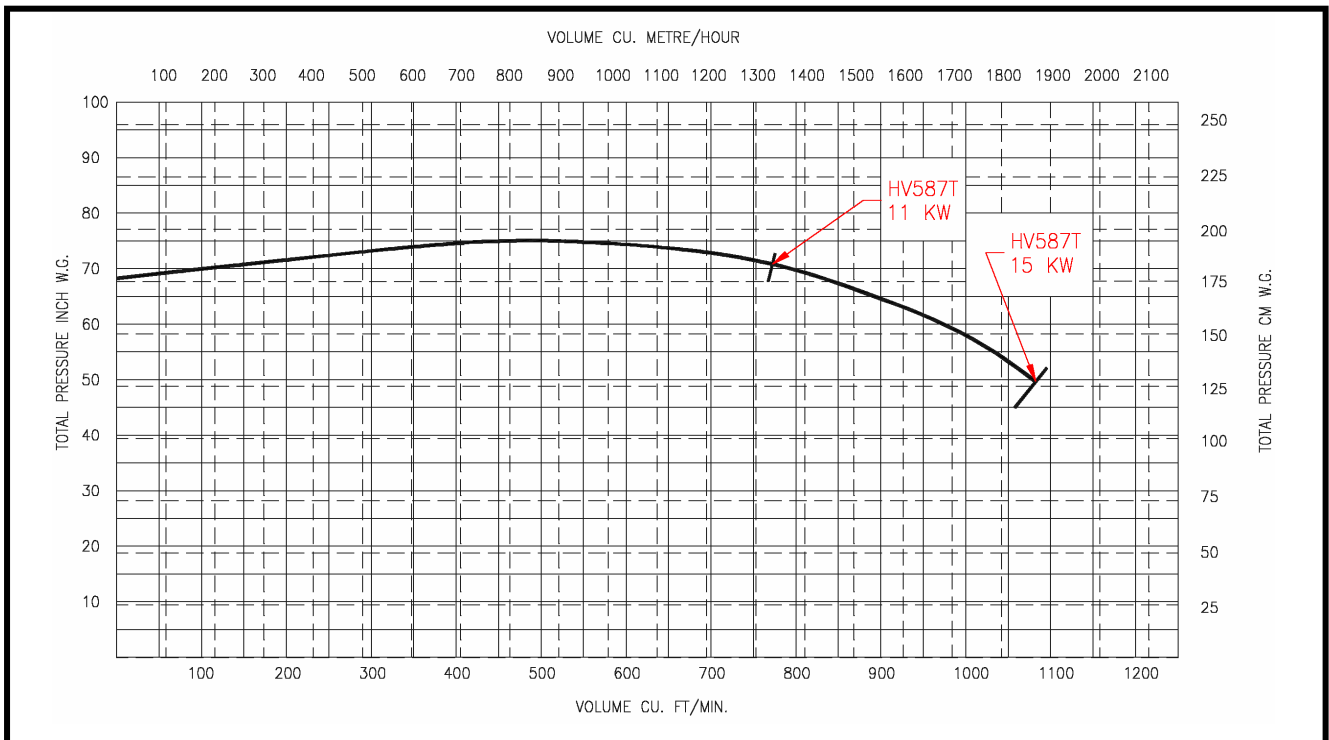
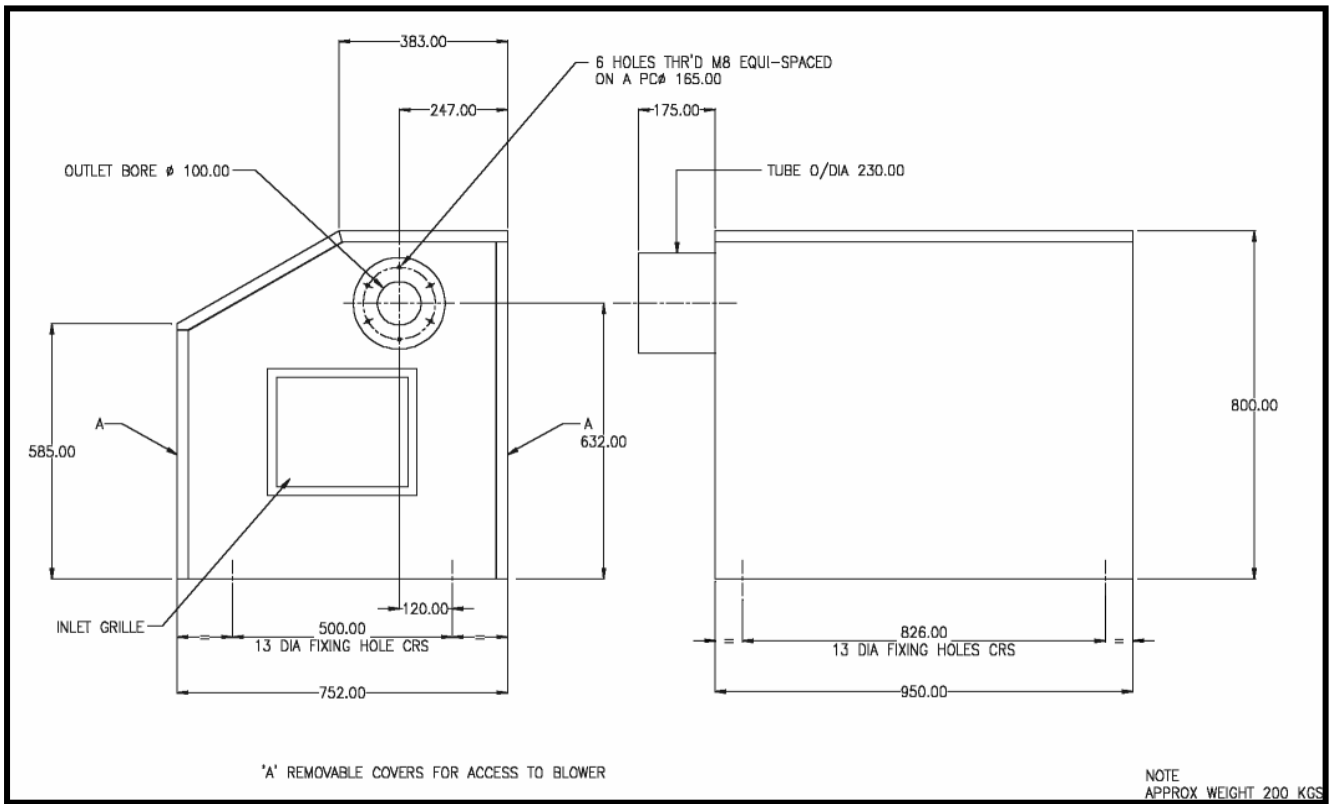

### Secomak

Honeypot Lane, Stanmore, Middlesex, HA7 1JR  
 Tel: +44 (0) 20 8952 5566 Fax: +44 (0) 20 8952 6983  
 E-mail: sales@secomak.com Web: www.secomak.com

A  
**HALMA**  
**GROUP**  
 COMPANY