

B30A

DESCRIPTION

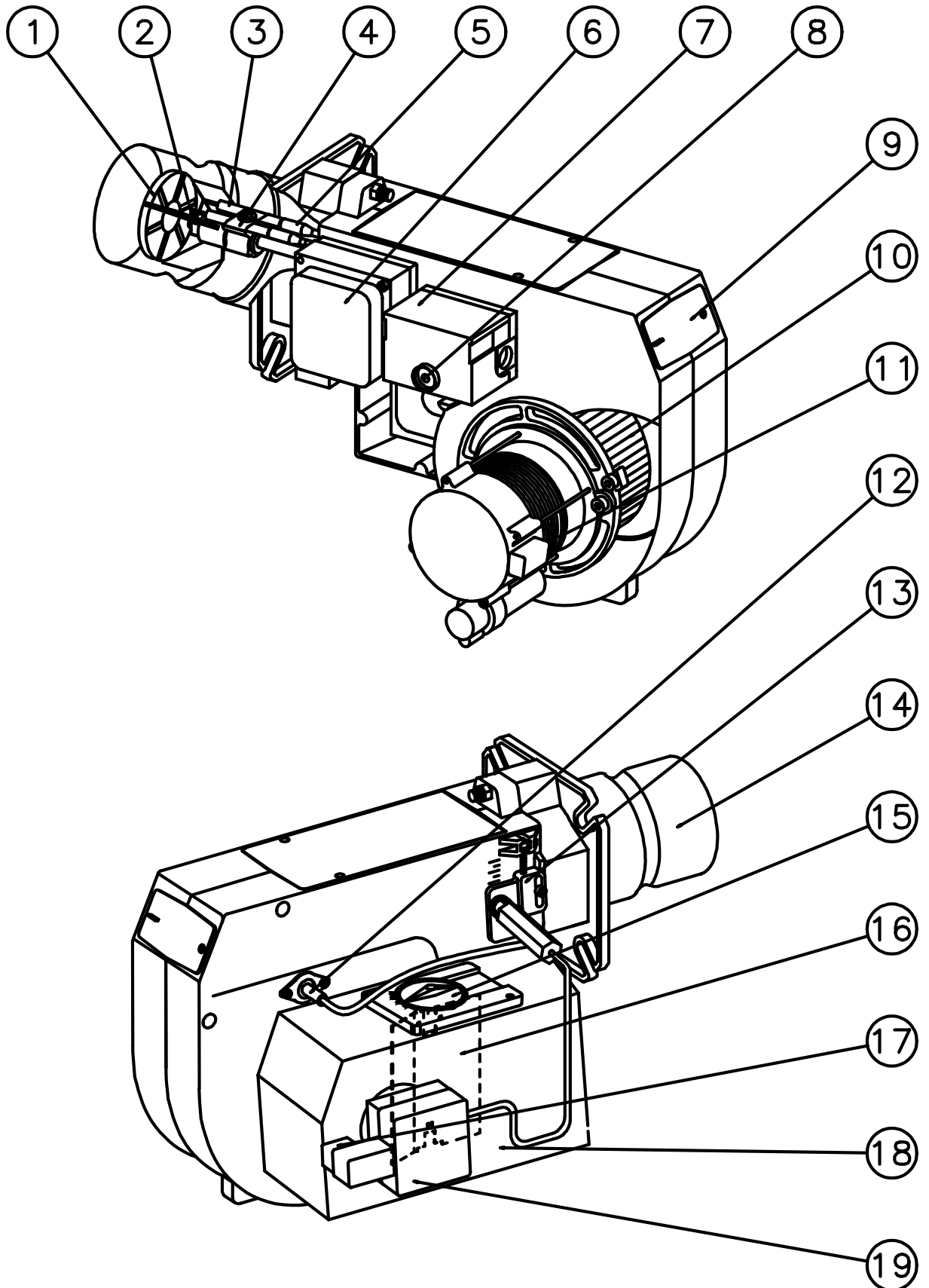

COMPONENTS

- | | | |
|-------------------------|--------------------------------|--------------------|
| 1. Shrouded disc | 8. Reset button | 14. Blast tube |
| 2. Nozzle | 9. Cover, inspection glass | 15. Air adjustment |
| 3. Ignition electrodes | 10. Fan wheel | 16. Air damper |
| 4. Nozzle assembly | 11. Motor | 17. Solenoid valve |
| 5. Ignition cable | 12. Photo cell | 18. Air intake |
| 6. Ignition transformer | 13. Nozzle assembly adjustment | 19. Pump |
| 7. Control box | | |

TECHNICAL DATA

Type designation B 30A

DIMENSIONS

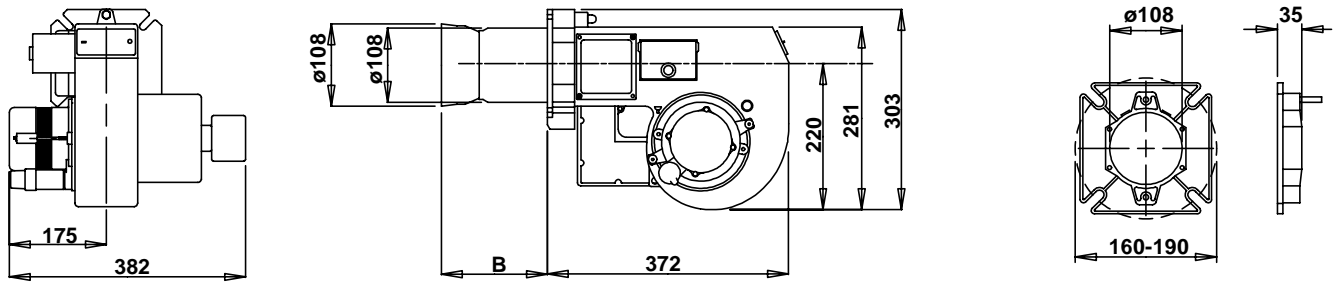

Burner tube	Length of burner tube	Measure B
L	150	115
L Standard	222	187

OUTPUT RANGE AND NOZZLES RECOMMENDED

Burnertube	Oil capacity kg/h	Output kW	Output Mcal/h	Recommended nozzle		Recommended Pump pressure
				Angle	Danfoss Monarch	
L	6,0-17,0	71-202	61-173	45° - 60°	S, B, R, PLP	10-15 bar

The net calorific value of 11,86 kWh/kg for light oil has been used.

RECOMMENDED NOZZLE

Because of different boiler types existing on the market, with varying combustion chamber designs, it is not

possible to state a definite spray angle or spray pattern.

Note that the spray angle and the spray pattern change with the pump pressure.

ELECTRODE ADJUSTMENT

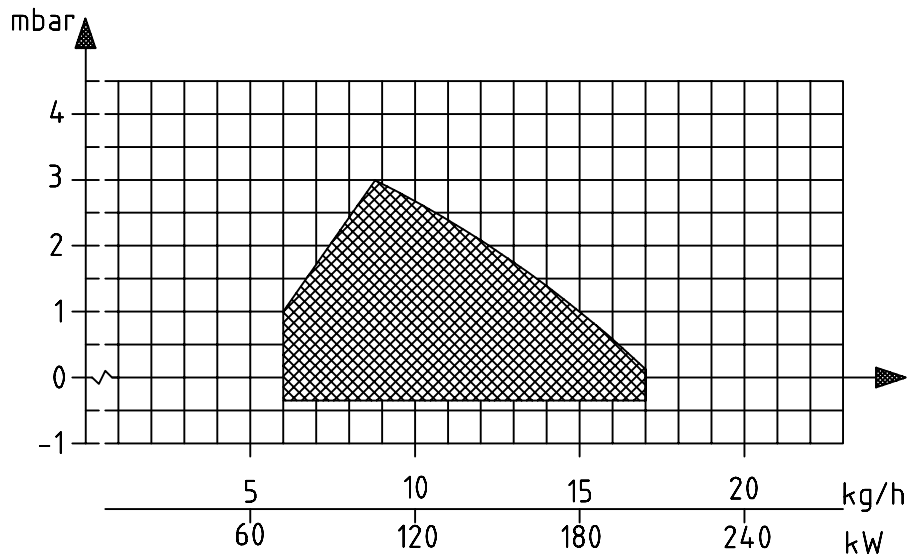
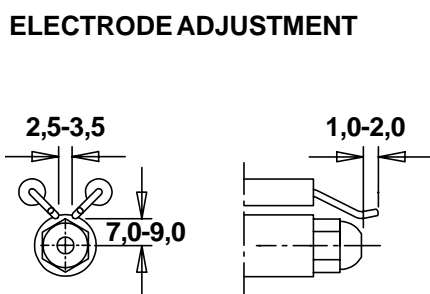

GENERAL INSTRUCTIONS

GENERAL RULES

The installation of an oil burner should be carried out in accordance with local regulations. The installer of the burner must therefore be aware of all regulations relating to oil and combustion.

Only oil suitable for the burner should be used and then in combination with a suitable oil filter before the oil pump of the burner.

If the burner is replacing an existing burner make sure that the oil filter is replaced or cleaned. The installation must only be undertaken by experienced personnel.

INSTALLATION INSTRUCTIONS

General installation instructions accompany the burner and should be left in a prominent place adjacent to the burner.

ADJUSTMENT OF BURNER

The burner is from the factory pre-set to an average value that must then be adjusted to the boiler in question.

All burner adjustments must be made in accordance with boiler manufacturers instructions. These must include the checking of flue gas temperatures, average water temperature and CO₂ or O₂ concentration.

To adjust the combustion device, start by increasing the air volume and the nozzle assembly somewhat. When the burner starts it is burning with excess air and smoke number 0. Reduce the nozzle assembly adjustment until soot occurs, and then increase the adjustment to make the soot disappear again. Then the volume of air is reduced until soot occurs and increased again to reach a combustion free of soot.

By this procedure an optimum adjustment is obtained. If larger nozzles are used the preadjustment of both the air volume and the nozzle assembly must be increased.

A whistling sound may be heard which can be eliminated or reduced as follows: Increase the nozzle assembly adjustment somewhat. The CO₂-content and consequently the air volume will then be reduced.

CONDENSATION IN CHIMNEY

A modern burner works with less excess air and often also with smaller nozzles than older models. This increases the efficiency but also the

risk of condensation in the chimney. The risk increases if the area of the chimney flue is too large. The temperature of the flue gases should exceed 60°C measured 0,5 metres from the chimney top.

Measures to raise the temperature:

Insulate the chimney in cold attics

Install a tube in the chimney

Install a draught regulator (dilutes the flue gases during operation and dries them up during standstill)

Increase the oil quantity

Raise the flue gas temperature by removing turbulators, if any, in the boiler.

PUMP ADJUSTMENT

See separate description.

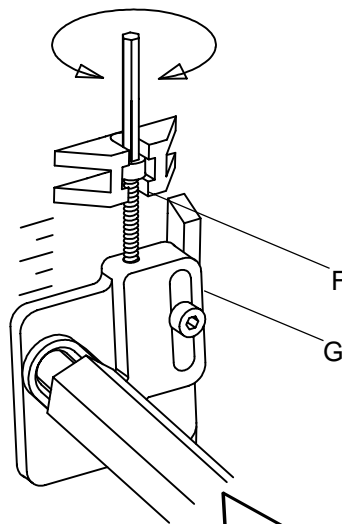

MAINTENANCE

The boiler/burner should be examined regularly for any signs of malfunction or oil leakage

OIL SUPPLY

The oil line should be dimensioned in accordance with the pump manufacturer's instruction. In the suction line to the burner a filter should be mounted to prevent any particles in the oil from reaching the burner. If the installation consists of several burners each one should have its own suction line from the tank or a circulation system should be used.

The temperature in the oil line should be kept as constant as possible. Avoid exposing the line to excessive cold which may cause blockages of paraffin deposits.

The oil pipe and electric cable should be fitted so that the burner can be placed on the floor for inspection of the combustion device.

ADJUSTMENT OF NOZZLE ASSEMBLY

Loosen the screw G and adjust the nozzle assembly by turning the screw F.

- | | | |
|-----------------|---|-----------------|
| Max. capacity | - | Front position |
| Medium capacity | - | Middle position |
| Min. capacity | - | Rear position |

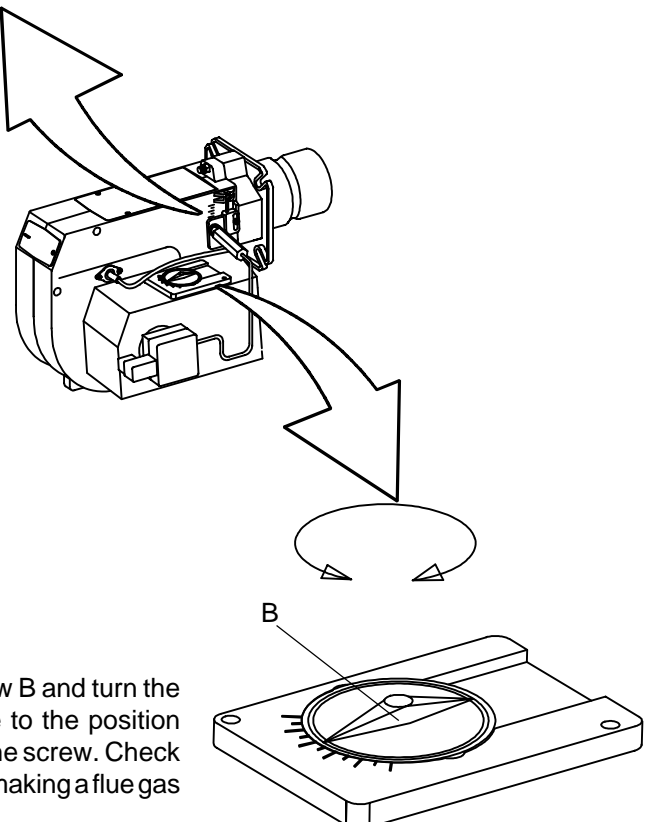

AIR ADJUSTMENT

Loosen the stop screw B and turn the knob along the scale to the position wanted and tighten the screw. Check the air adjustment by making a flue gas analysis.

MAINTENANCE

Warning: Before doing any service switch off power at the main switch and cut off the oil supply.

SERVICE OF BURNER HEAD

Open the cover and disconnect the connecting pipes by loosening screw A.

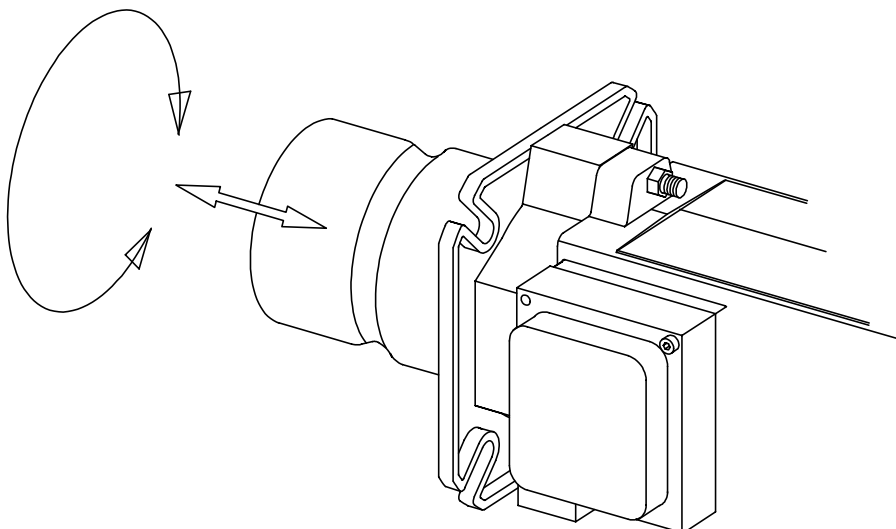
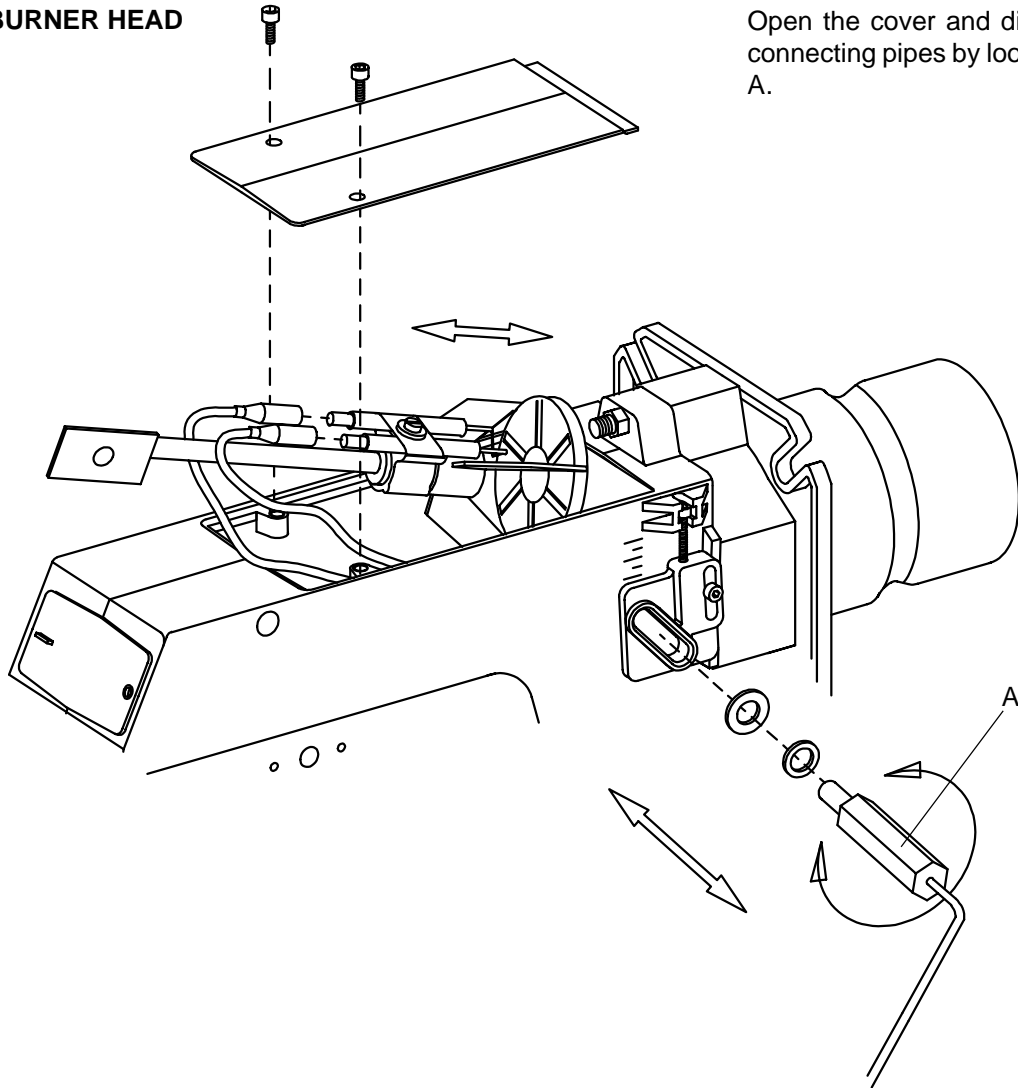

1. Loosen or swing out the burner from the boiler.
2. Turn the blast tube to the left and withdraw it.

ELECTRIC EQUIPMENT

OIL BURNER CONTROL: LOA21.173A27/LOA24.173A27/BHO61.A/B

FUNCTION

1. Switch on operating switch and twin thermostat
The burner motor starts, an ignition spark is formed, the prepurge goes on till the prepurge period expires and the solenoid valve opens (2).
2. Solenoid valve opens
Oil mist is formed and ignited. The photocell indicates a flame. The ignition spark goes out 2 s. after flame indication when the ignition transformer is connected to terminal 7.
3. The safety time expires
 - a. If no flame is established before this time limit the control cuts out.
 - b. If for some reasons the flame disappears after this time limit, the burner will make an attempt to re-start.
- 3-4. Operating position
If the burner operation is interrupted by means of the main switch or the thermostat, a new start takes place when the conditions in accordance with point 1 are fulfilled.

The oil burner control cuts out

A red lamp in the control is lit. Press the reset button and the burner re-starts.

Post-ignition

If a post-ignition of 15 s. is wanted, move the ignition transformer from terminal 7 to terminal 6.

LIST OF COMPONENTS

A1 Oil burner control	R1 Photoresistor
A2 Twin thermostat	S3 Main switch
F1 Fuse, max. 10A	T1 Ignition transformer
H1 Alarm lamp	Y1 Solenoid valve
H2 Signal lamp (optional)	X1 Plug-in contact, burner
M1 Burner motor	X2 Plug-in contact, boiler
P1 Time meter (optional)	

Mains connection and fuses in accordance with local regulations.

TECHNICAL DATA

Pre-ignition time:	13 s
Pre-purge time:	13 s
Post-ignition time:	2 s
Safety lock-out time:	10 s
Reset time after lockout:	min. 50 s
Reaction time on flame failure:	max. 1 s
Ambient temperature:	from - 20 to +60°C
Min. current with flame established:	65 μ A
Max. photo current at start:	5 μ A
Enclosure:	IP 40

(Under voltage proof only LOA24.173A27)

CONTROL OF PHOTOCURRENT

Current through photo unit is measured with a d.c. ammeter (a moving coil instrument connected in series with the photo unit).

WIRING DIAGRAM

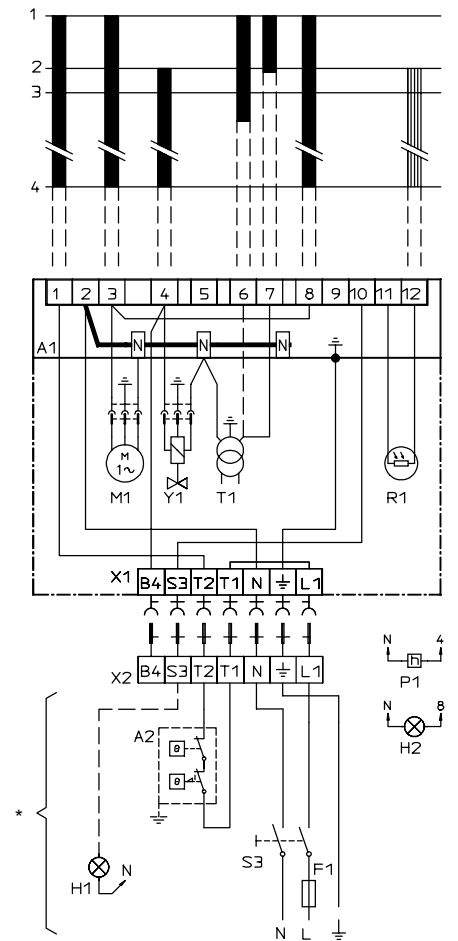

* If there is no plug-in contact (X2) on the boiler, connect to the contact enclosed. In case the twin thermostat is in series on incoming phase L1, a loop between the terminals T1 and T2 is necessary.

OUTER ELECTRICAL CONNECTION

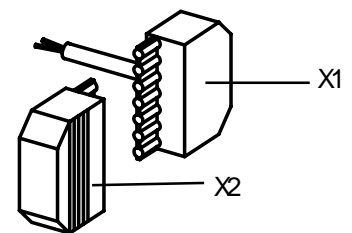

INSTRUCTIONS PUMP TYPE SUNTEC AS47C

TECHNICAL DATA

Viscosity range: 1-12 mm²/s
 Pressure range: 7-12 bar
 Oil temperature: max 60°C

COMPONENTS

1. Pressure adjustment
2. By-pass plug
3. Nozzle outlet G 1/8"
4. Pressure gauge port G 1/8"
5. Vacuum gauge port G 1/8"
6. Return line G 1/4"
and internal by-pass plug
7. Suction line G 1/4"
8. Pressure gauge port G 1/8"

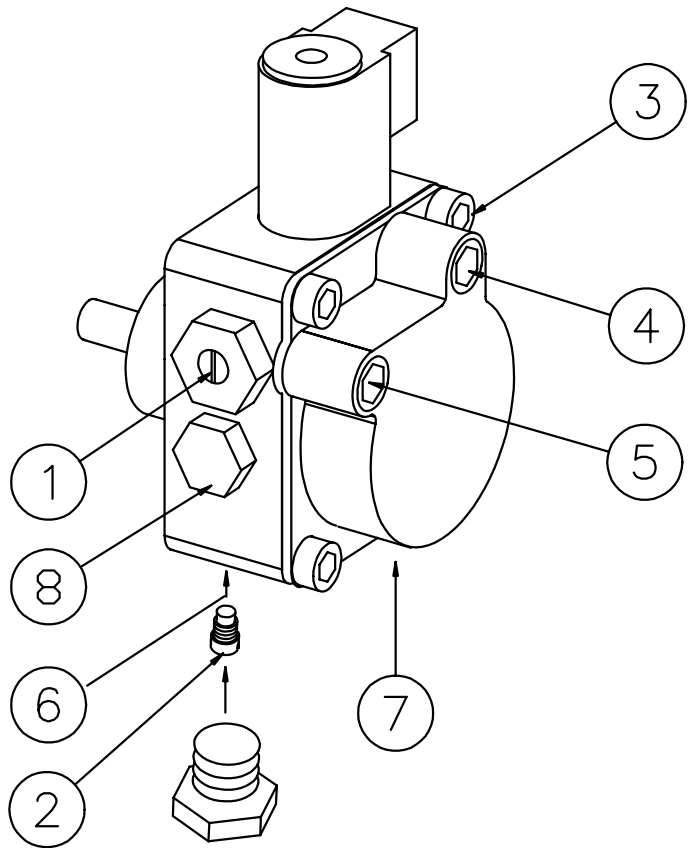

SUCTION LINE TABLES

The suction line tables consist of theoretically calculated values where the pipe dimensions and oil velocity have been matched so that turbulences will not occur. Such turbulences will result in increased pressure losses and in acoustic noise in the pipe system. In addition to drawn copper piping a pipe system usually comprises 4 elbows, a non-return valve, a cut-off valve and an external oil filter.

The sum of these individual resistances is so insignificant that they can be disregarded. The tables do not include any lengths exceeding 100 m as experience shows that longer lengths are not needed.

The tables apply to a standard fuel oil of normal commercial quality according to current standards. On commissioning with an empty tube system the oil pump should not be run without oil for more than 5 min. (a condition is that the pump is being lubricated during operation).

The tables state the total suction line length in metres at a nozzle capacity of 2,1 kg/h. Max. permissible pressure at the suction and pressure side is 2,0 bar. For two-pipe system Q_{max} 46 l/h pump capacity at 0 bar.

1-pipe system <table border="1"> <thead> <tr> <th>Height</th> <th>Pipe diameter</th> </tr> </thead> <tbody> <tr> <td>H</td> <td>ø4 mm</td> </tr> <tr> <td>m</td> <td>m</td> </tr> <tr> <td>4,0</td> <td>100</td> </tr> <tr> <td>3,0</td> <td>100</td> </tr> <tr> <td>2,0</td> <td>100</td> </tr> <tr> <td>1,0</td> <td>91</td> </tr> <tr> <td>0,5</td> <td>82</td> </tr> <tr> <td>0,0</td> <td>74</td> </tr> </tbody> </table>	Height	Pipe diameter	H	ø4 mm	m	m	4,0	100	3,0	100	2,0	100	1,0	91	0,5	82	0,0	74	1-pipe system <table border="1"> <thead> <tr> <th>Height</th> <th>Pipe diameter</th> </tr> </thead> <tbody> <tr> <td>H</td> <td>ø4 mm</td> </tr> <tr> <td>m</td> <td>m</td> </tr> </tbody> </table> <p>With an underlying tank a 1-pipe-system is not recommended</p>	Height	Pipe diameter	H	ø4 mm	m	m												
Height	Pipe diameter																																				
H	ø4 mm																																				
m	m																																				
4,0	100																																				
3,0	100																																				
2,0	100																																				
1,0	91																																				
0,5	82																																				
0,0	74																																				
Height	Pipe diameter																																				
H	ø4 mm																																				
m	m																																				
Two-pipe system <table border="1"> <thead> <tr> <th>Height</th> <th>Pipe diameter</th> </tr> </thead> <tbody> <tr> <td>H</td> <td>ø6 mm</td> </tr> <tr> <td>m</td> <td>m</td> </tr> <tr> <td>4,0</td> <td>29</td> </tr> <tr> <td>3,0</td> <td>25</td> </tr> <tr> <td>2,0</td> <td>22</td> </tr> <tr> <td>1,0</td> <td>18</td> </tr> <tr> <td>0,5</td> <td>16</td> </tr> <tr> <td>0,0</td> <td>14</td> </tr> </tbody> </table>	Height	Pipe diameter	H	ø6 mm	m	m	4,0	29	3,0	25	2,0	22	1,0	18	0,5	16	0,0	14	Two-pipe system <table border="1"> <thead> <tr> <th>Height</th> <th>Pipe diameter</th> </tr> </thead> <tbody> <tr> <td>H</td> <td>ø6 mm</td> </tr> <tr> <td>m</td> <td>m</td> </tr> <tr> <td>0,0</td> <td>14</td> </tr> <tr> <td>-0,5</td> <td>12</td> </tr> <tr> <td>-1,0</td> <td>10</td> </tr> <tr> <td>-2,0</td> <td>7</td> </tr> <tr> <td>-3,0</td> <td>3</td> </tr> <tr> <td>-4,0</td> <td>0</td> </tr> </tbody> </table>	Height	Pipe diameter	H	ø6 mm	m	m	0,0	14	-0,5	12	-1,0	10	-2,0	7	-3,0	3	-4,0	0
Height	Pipe diameter																																				
H	ø6 mm																																				
m	m																																				
4,0	29																																				
3,0	25																																				
2,0	22																																				
1,0	18																																				
0,5	16																																				
0,0	14																																				
Height	Pipe diameter																																				
H	ø6 mm																																				
m	m																																				
0,0	14																																				
-0,5	12																																				
-1,0	10																																				
-2,0	7																																				
-3,0	3																																				
-4,0	0																																				

APPLICATIONS FOR SUNTEC AS47C

- Light fuel oil and kerosine.
- Nozzle flow up to 46 l/h (approx. 395 000 kcal/h - 470 kW).
- One or two-pipe system.

PUMP OPERATING PRINCIPLE

The SUNTEC AS oil pump has a built in solenoid valve which controls the regulator cut-off valve giving fast cut-off and cut-on function independent of the rotational speed.

The gear-set draws oil from the tank through the built-in filter and transfers it to the valve that regulates the oil pressure to the nozzle line.

All oil which does not go through the nozzle line will be dumped through the valve back to the return line or, if it is a one-pipe installation, back to the suction port in the gear-set.

- TWO-PIPE OPERATION

When the solenoid valve is non-activated, the by-pass channel between the pressure and return sides of the valve is open.

No pressure will then be built up to open the valve. It does not matter which speed the gear set has.

When the solenoid is activated, this by-pass channel will be closed and because of the full speed of the gear-set, the pressure necessary to open the valve will be built up very rapidly which gives a very sharp cut-on function.

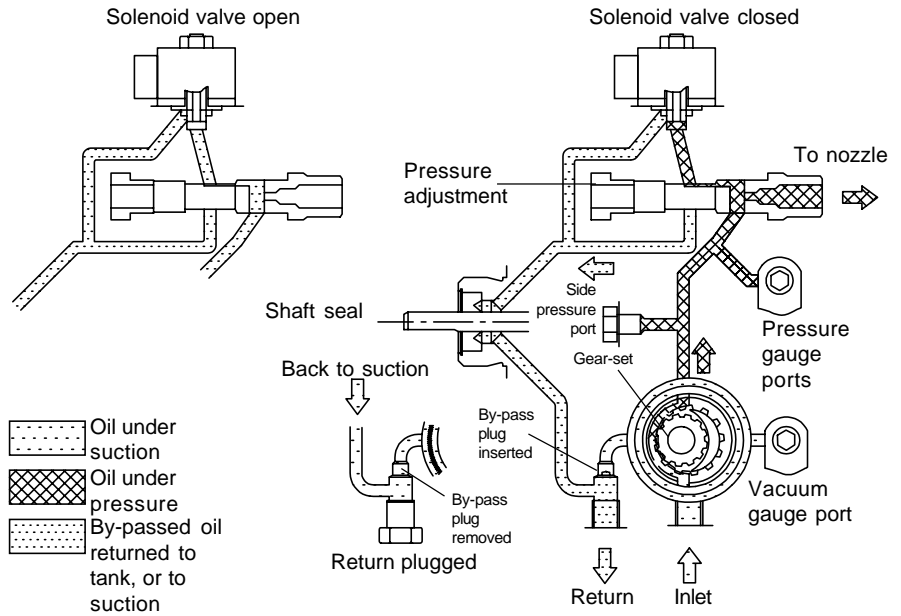

One pipe installation

Two pipe installation

- ONE-PIPE OPERATION

Bleeding on one-pipe is not automatic, and a pressure port must be opened to bleed the system.

CUT-OFF

When the burner stops, the solenoid opens the by-pass at the same moment which drains all the oil down to the return and the nozzle valve closes immediately. This gives a very sharp cut-off function.

The cut-on and off can be regulated regardless of motor speed and has an extremely fast response.

When the solenoid is non-activated, the torque requirement is low up to full motor speed.

Shaft rotation and nozzle location
C: Anti-clock. rotation/
Left hand nozzle (seen from Shaft end)

Gear set capacity
(see pump capacity curves)

AS: Solenoid valve with cut-off

AS 47 C

EXCHANGE OF FILTER

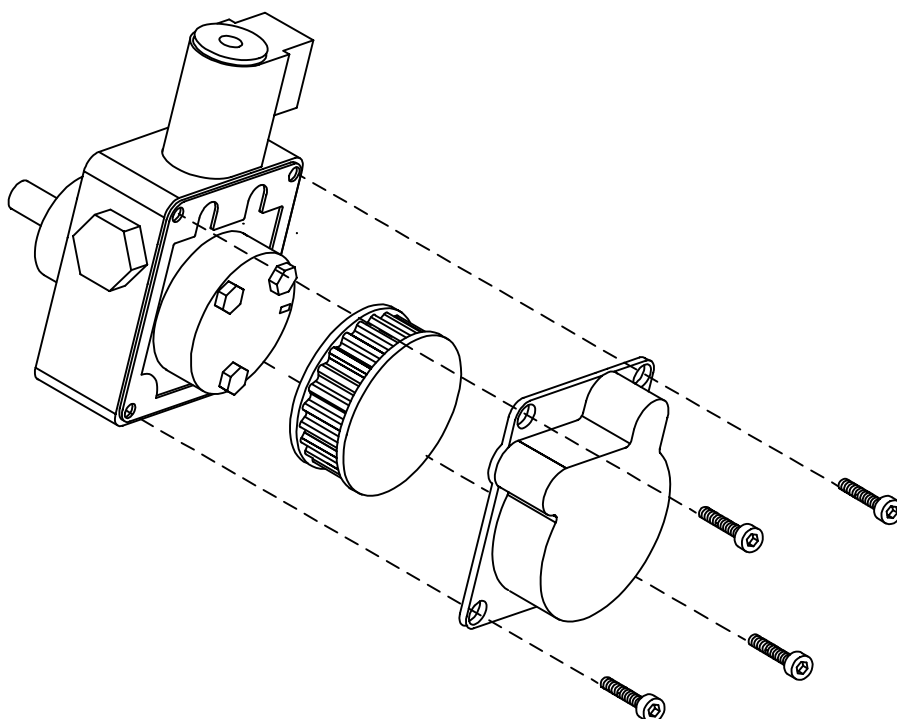

MOUNTING/DISMOUNTING RETURN PLUG

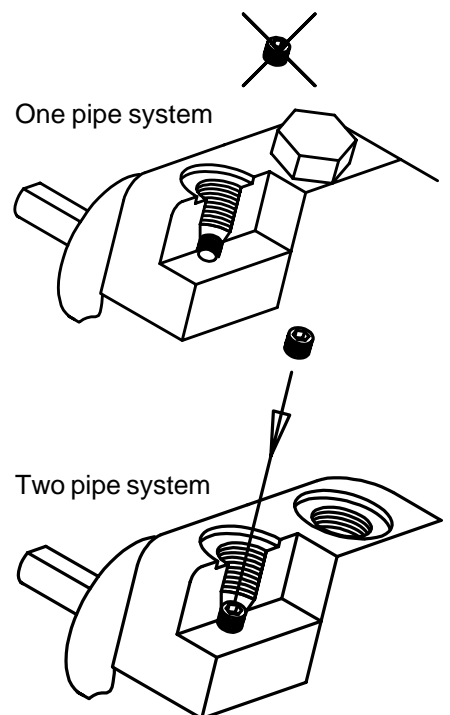

NOZZLE TABLE

Pump pressure bar

Gph	8			9			10			11			12			13			14			15		
	kg/h	kW	Mcal/h	kg/h	kW	Mcal/h	kg/h	kW	Mcal/h	kg/h	kW	Mcal/h	kg/h	kW	Mcal/h	kg/h	kW	Mcal/h	kg/h	kW	Mcal/h	kg/h	kW	Mcal/h
0,40	1,33	16	13	1,41	17	14	1,49	18	15	1,56	18	16	1,63	19	17	1,70	20	17	1,76	21	18	1,82	21	18
0,50	1,66	20	17	1,76	21	18	1,86	22	19	1,95	23	20	2,04	24	21	2,12	25	22	2,20	26	22	2,28	27	23
0,60	2,00	24	20	2,12	25	22	2,23	26	23	2,34	28	24	2,45	29	25	2,55	30	26	2,64	31	27	2,73	32	28
0,65	2,16	26	22	2,29	27	23	2,42	29	25	2,54	30	26	2,65	31	27	2,75	33	28	2,86	34	29	2,96	35	30
0,75	2,49	29	25	2,65	31	27	2,79	33	28	2,93	35	30	3,08	36	31	3,18	38	32	3,30	39	34	3,42	40	35
0,85	2,83	33	29	3,00	36	31	3,16	37	32	3,32	39	34	3,47	41	35	3,61	43	37	3,74	44	38	3,87	46	39
1,00	3,33	39	34	3,53	42	36	3,72	44	38	3,90	46	40	4,08	48	42	4,24	50	43	4,40	52	45	4,56	54	46
1,10	3,66	43	37	3,88	46	39	4,09	48	42	4,29	51	44	4,48	53	46	4,67	55	48	4,84	57	49	5,01	59	51
1,20	3,99	47	41	4,24	50	43	4,47	53	46	4,68	55	48	4,89	58	50	5,09	60	52	5,29	63	54	5,47	65	56
1,25	4,16	49	42	4,40	52	45	4,65	55	47	4,88	58	50	5,10	60	52	5,30	63	54	5,51	65	56	5,70	68	58
1,35	4,49	53	46	4,76	56	48	5,02	59	51	5,27	62	54	5,50	65	56	5,73	68	58	5,95	70	61	6,15	73	63
1,50	4,98	59	51	5,29	63	54	5,58	66	57	5,85	69	60	6,11	72	62	6,36	75	65	6,60	78	67	6,83	81	70
1,65	5,49	65	56	5,82	69	59	6,14	73	63	6,44	76	66	6,73	80	69	7,00	83	71	7,27	86	74	7,52	89	77
1,75	5,82	69	59	6,18	73	63	6,51	77	66	6,83	81	70	7,14	85	73	7,42	88	76	7,71	91	79	7,97	94	81
2,00	6,65	79	68	7,06	84	72	7,45	88	76	7,81	93	80	8,18	97	83	8,49	101	86	8,81	104	90	9,12	108	93
2,25	7,49	89	76	7,94	94	81	8,38	99	85	8,78	104	89	9,18	109	94	9,55	113	97	9,91	117	101	10,26	122	105
2,50	8,32	99	85	8,82	105	90	9,31	110	95	9,76	116	99	10,19	121	104	10,61	126	108	11,01	130	112	11,39	135	116
2,75	9,15	108	93	9,71	115	99	10,24	121	104	10,73	127	109	11,21	133	114	11,67	138	119	12,11	144	123	12,53	148	128
3,00	9,98	118	102	10,59	126	108	11,16	132	114	11,71	139	119	12,23	145	125	12,73	151	130	13,21	157	135	13,67	162	139
3,50	11,65	138	119	12,35	146	126	13,03	154	133	13,66	162	139	14,27	169	145	14,85	176	151	15,42	183	157	15,95	189	163
4,00	13,31	158	136	14,12	167	144	14,89	176	152	15,62	185	159	16,31	193	166	16,97	201	173	17,62	209	180	18,23	216	186
4,50	14,97	177	153	15,88	188	162	16,75	198	171	17,57	208	179	18,35	217	187	19,10	226	195	19,82	235	202	20,51	243	209
5,00	16,64	197	170	17,65	209	180	18,62	221	190	19,52	231	199	20,39	242	208	21,22	251	216	22,03	261	225	22,79	270	232
5,50	18,30	217	187	19,42	230	198	20,48	243	209	21,47	255	219	22,43	266	229	23,34	277	238	24,23	287	247	25,07	297	256
6,00	19,97	237	204	21,18	251	216	22,34	265	228	23,42	278	239	24,47	290	249	25,46	302	260	26,43	313	269	27,49	326	280
6,50	21,63	256	220	22,94	272	234	24,20	287	247	25,37	301	259	26,51	314	270	27,58	327	281	28,63	339	292	29,63	351	302
7,00	23,29	276	237	24,71	293	252	26,06	309	266	27,33	324	279	28,55	338	291	29,70	352	303	30,84	366	314	31,91	378	325
7,50	24,96	296	254	26,47	314	270	27,92	331	285	29,28	347	298	30,59	363	312	31,83	377	324	33,04	392	337	34,19	405	349
8,00	26,62	316	271	28,24	335	288	29,79	353	304	31,23	370	318	32,63	387	333	33,95	403	346	35,25	418	359	36,47	432	372
8,50	28,28	335	288	30,00	356	306	31,65	375	323	33,18	393	338	34,66	411	353	36,07	428	368	37,45	444	382	38,74	459	395
9,00	29,95	355	305	31,77	377	324	33,59	398	342	35,14	417	358	36,71	435	374	38,19	453	389	39,65	470	404	41,02	486	418

 The table applies to oil with a viscosity of 4,4 mm²/s (cSt) with density 830 kg/m³.

BURNER WITH PREHEATER

Consider that on preheating the oil quantity is reduced by 5-20% depending on.

- Rise in temperature at the nozzle
- Design of nozzle
- Capacity (high capacity - small difference)

FAULT LOCATION

BURNER FAILS TO START

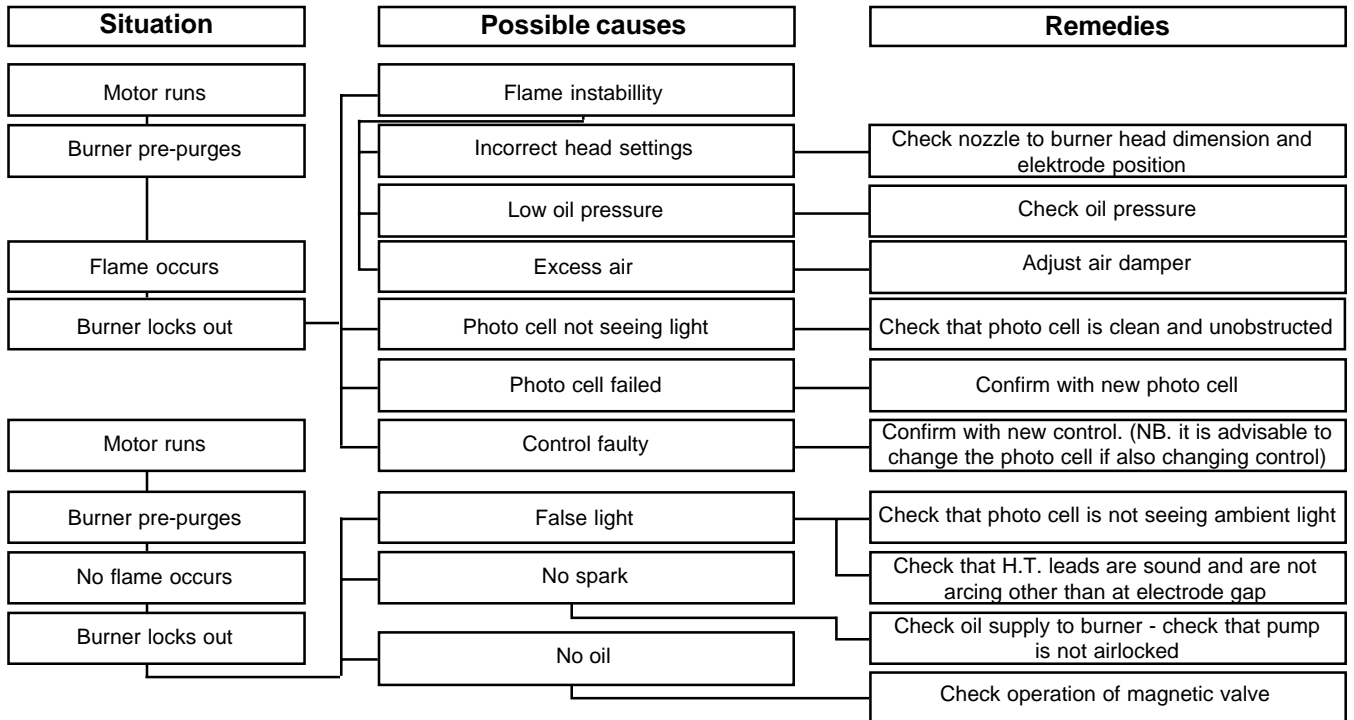

BURNER FAILS TO START AFTER NORMAL OPERATION

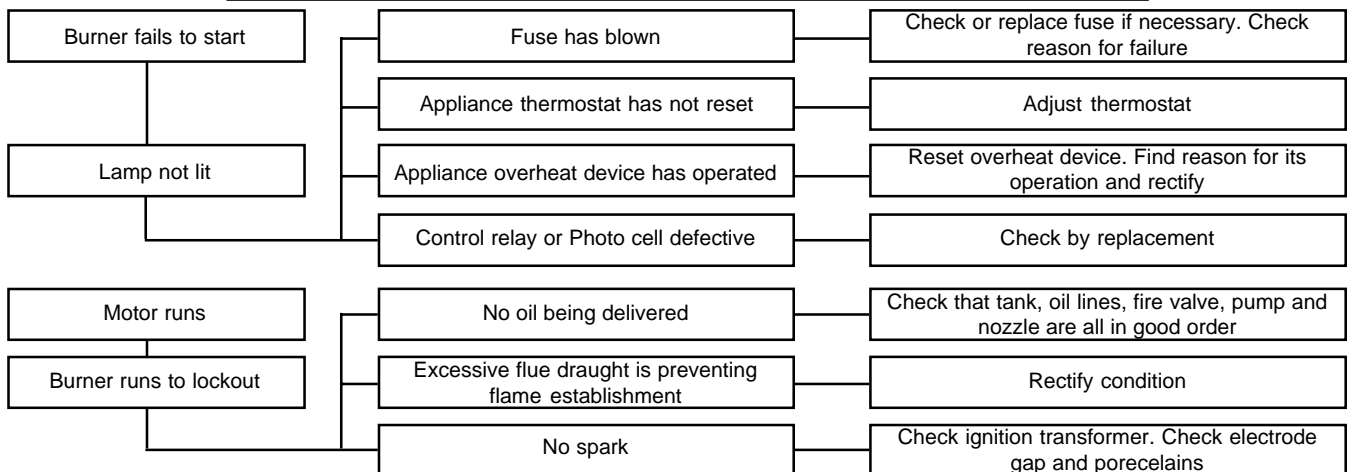

DELAYED IGNITION, BURNERS STARTS VIOLENTLY

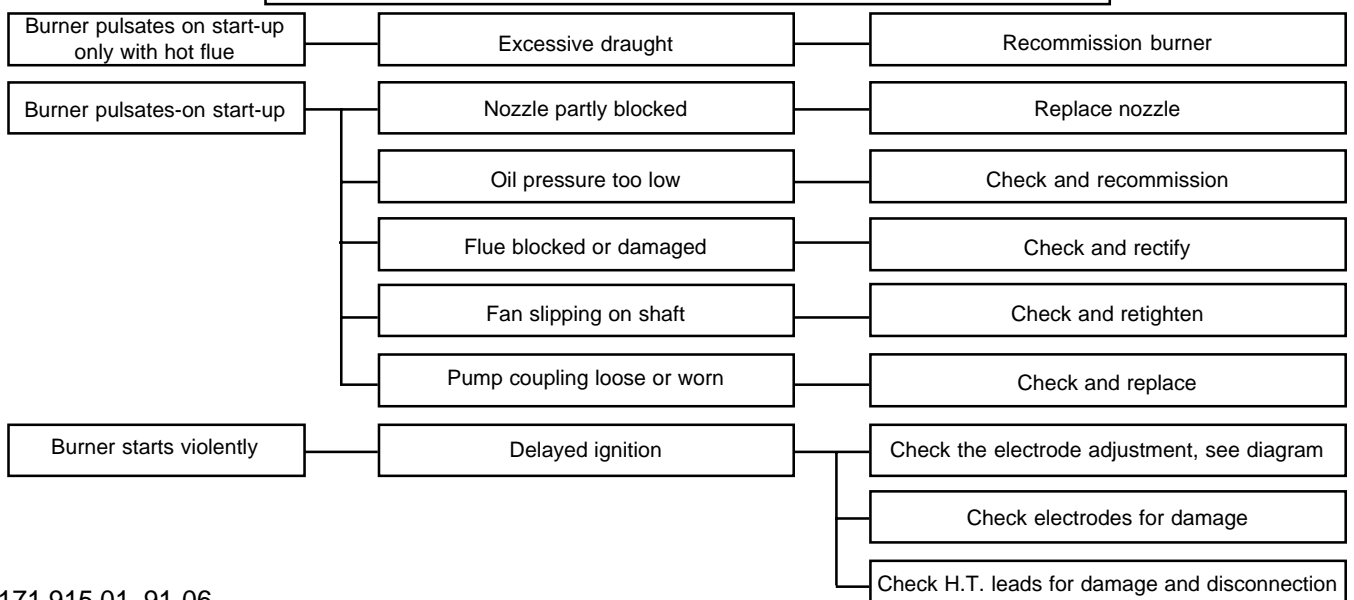

DECLARATION OF CONFORMITY

We
(supplier's name)

BENTONE AB

(address)

P.O. Box 309, S-341 26 Ljungby, Sverige

declare under our sole responsibility that the product
(name, type or model, batch or serial number, possibly sources and number of items)

ST 97, ST 108, ST 120, ST 133, ST 146, B 9, B 10, B 11, B 20, B 30, B 40, B 45, B 50, B 60, B 70, B 80, SF 141

and TF 205, fan burners for gasoil

to which this declaration relates is in conformity with the following standard(s) or the normative document(s)
(title and/or number and date of issue of the standard(s) or other normative document(s))

DIN 4787 and EN 267

following the provisions of Directive
(if applicable)

EMC directive 89 / 336 / EEC, Low voltage directive 73 / 23 / EEC and Machinery directive 89/392/EEC.

Re. the Efficiency directive 92/42/EEC, please see the next page.

Ljungby, 25th May, 1999

(Place and date of issue)

BENTONE AB

Ulf Bondeson

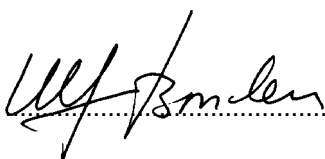

(name and signature of equivalent marking of authorized person)

To fulfil the demands according to the Efficiency directive 92/42/EEC, Article 2, we herewith state the following parameters.

Burner type	Capacity kg/h (kW)	Test report No. TÜV	Pressure in combustion chamber mbar	Product ID-No. as per EC-Type Examination Certificate
ST 97	1,2-2,6 (14,2-30,8)	3728 (15.03.96)	-0,2 to+1,4 to + 0,1	CE 0036 0128/98
ST 108	1,2-3,8 (14,2-45)	3729 (15.03.96)	-0,2 to + 1,4 to + 0,2	CE 0036 0129/98
ST 120	2,1-4,5 (24,9-53,3)	3581 (10.11.94)	-0,2 to + 1,9 to + 0,2	CE 0036 0130/98
ST 133	2,0-10,0 (23,7-118,5)	3795 (12.11.96)	-0,2 to + 2,2 to + 0,1	CE 0036 0131/98
ST 146	4,0-10,0 (47,4-118,5)	3796 (12.11.96)	-0,2 to + 3,9 to + 0,1	CE 0036 0132/98
B 9	1,2-2,5 (14,2-29,6)	3341 (21.08.92)	-0,2 to + 0,8 to + 0,1	CE 0036 0133/98
B 10	1,4-3,0 (16,6-35,6)	3465 (03.09.93)	-0,2 to + 1,1 to + 0,25	CE 0036 0134/98
B 10KA	2,0-4,6 (23,7-54,5)	3778 (18.10.96)	-0,2 to + 0,95 to + 0,1	CE 0036 0135/98
B 10ZHV	1,2-2,5 (14,2-29,5)	3525 (21.01.94)	-0,2 to + 1,0 to + 0,3	CE 0036 0136/98
B 11				
B 20K	4,3-9,8 (51,0-116,1)	3779 (18.10.96)	-0,2 to + 1,15 to + 0,1	CE 0036 0137/98
B 20KA	2,0-8,0 (23,7-94,8)	3333 (04.08.92)	-0,2 to 0,78 to + 0,1	CE 0036 0138/98
B 20ZHV	2,1-4,3 (24,9-51,0)	3397 (14-06.93)	-0,2 to 1,25 to + 0,1	CE 0036 0139/98
B 30	6,0-17,5 (71,1-207,4)	3524 (24.01.94)	-0,2 to + 2,8 to + 0,2	CE 0036 0140/98
B 30A	6,0-17,0 (71,1-207,4)	3797 (12.11.96)	-0,2 to + 3,0 to + 0,1	CE 0036 0141/98
B 30A2	4,5-15,0 (53,3-177,8)	3798 (12.11.96)	-0,2 to 3,8 to + 0,1	CE 0036 0142/98
B 30ZHV-2	3,3-10,0 (39,1-118,5)	3563 (10.11.94)	-0,2 to + 1,3 to + 0,1	CE 0036 0143/98
B 40	9,0-29,5 (106,7-349,6)	3503 (21.09.93)	-0,3 to + 4,1 to + 0,2	CE 0036 0144/98
B 40A	9,0-29,5 (106,7-349,6)	3799 (12.11.96)	-0,2 to + 5,3 to + 0,1	CE 0036 0145/98

To fulfil the demands according to the Efficiency directive 92/42/EEC, Article 2, we herewith state the following parameters.

Burner type	Capacity kg/h (kW)	Test report No. TÜV	Pressure in combustion chamber mbar	Product ID-No. as per EC-Type Examination Certificate
B 50-2F	12,0-59,0 (142,2-699,2)	3390 (09.06.93)	-0,2 to +9,4 to + 0,2	CE 0036 0147/98
B 50-3F	12,0-59,0 (142,2-699,2)	3592 (10.11.94)	-0,2 to + 9,25 to + 0,1	CE 0036 0148/98
B 60-2F	20,0-90,0 (237,0-1066,5)	3466 (03.09.93)	-0,3 to + 11,4 to + 0,8	CE 0036 0149/98
B 60-3F	20,0-90,0 (237,0-1066,5)	3591 (10.11.94)	-0,3 to + 11,4 to + 0,8	CE 0036 0150/98
B 70				
B 80				
SF 141-3	50,0-140,0 (592,5-1659,0)	3502 (16.09.93)	-0,7 to 8,7 to + 12,0 to + 0,1	CE 0036 0151/98
TF 205-3	70,0-205,0	3501 (16.09.93)	-0,7 to + 14,0 to + 16,0 to + 0,1	CE 0036 0152/98
B45A	8,5-47,0 (100,8-557,5)	3977 (16.04.99)	-0,1 to + 0,4 to + 7,0	CE 0036 0250/99
B45A2	8,5-45,5 (100,8-539,7)	3978 (16.04.99)	-0,1 to + 0,4 to + 7,5	CE 0036 0251/99