

B40A2.2H

DESCRIPTION

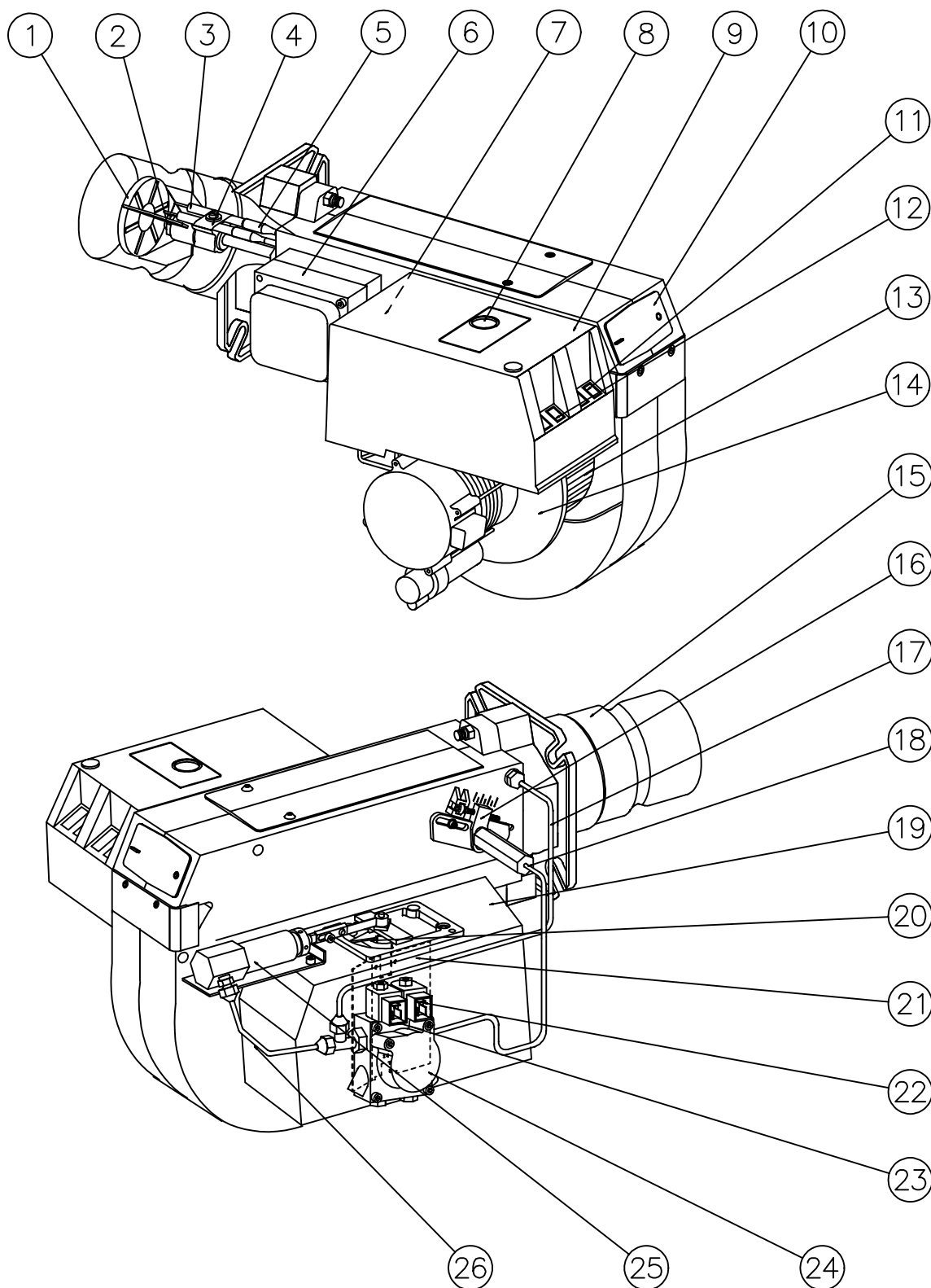

COMPONENTS

- | | | |
|-------------------------|--------------------------------|--|
| 1. Brake plate | 10. Cover, inspection glass | 19. Air intake |
| 2. Nozzle | 11. Indicating lamp | 20. Scale, air damper |
| 3. Ignition electrodes | 12. Change-over switch | 21. Air damper |
| 4. Nozzle assembly | 13. Fan wheel | 22. Solenoid valve |
| 5. Ignition cable | 14. Motor | 23. Solenoid valve |
| 6. Ignition transformer | 15. Blast tube | 24. Pump |
| 7. Photo cell | 16. Nozzle assembly adjustment | 25. Adjustment device |
| 8. Reset button | 17. Connecting pipe Stage 2 | 26. Connecting pipe,
pump-adjustment device |
| 9. Electric panel | 18. Connecting pipe Stage 1 | |

TECHNICAL DATA

Type designation B40A2-2

DIMENSIONS

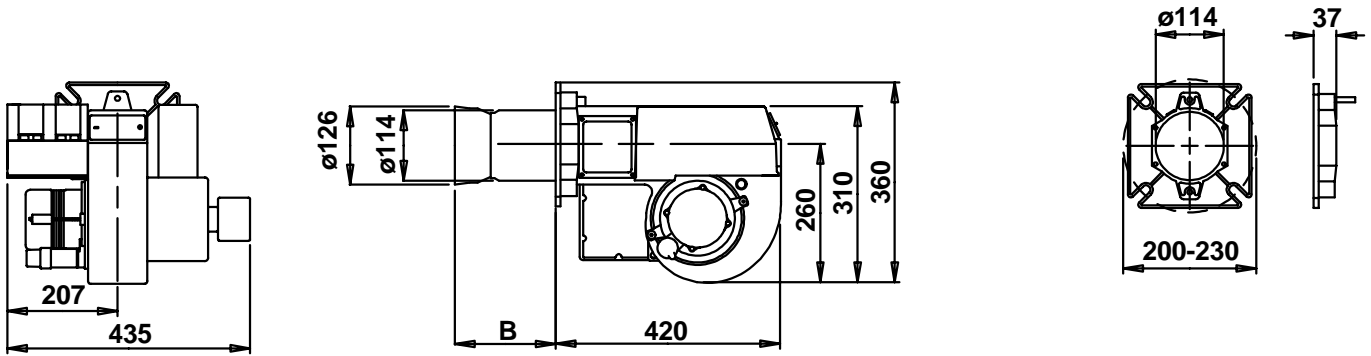

Burner tube	Length of burner tube	Measure B
A	204	174
A	304	274

OUTPUT RANGE AND NOZZLES RECOMMENDED

Burner tube	Oil capacity			Recommended Nozzle		Recommended Pump pressure
	kg/h	kW	Mcal/h	Angle	Type	Bar
A	8,0-29,5	95-350	82-301	45° - 60°	S, B, R, PLP	14

The net calorific value of 11,86 kWh/kg for light oil has been used.

RECOMMENDED NOZZLE

Because of different boiler types existing on the market, with varying combustion chamber designs, it is not

possible to state a definite spray angle or spray pattern.

Note that the spray angle and the spray pattern change with the pump pressure.

BURNER HEAD

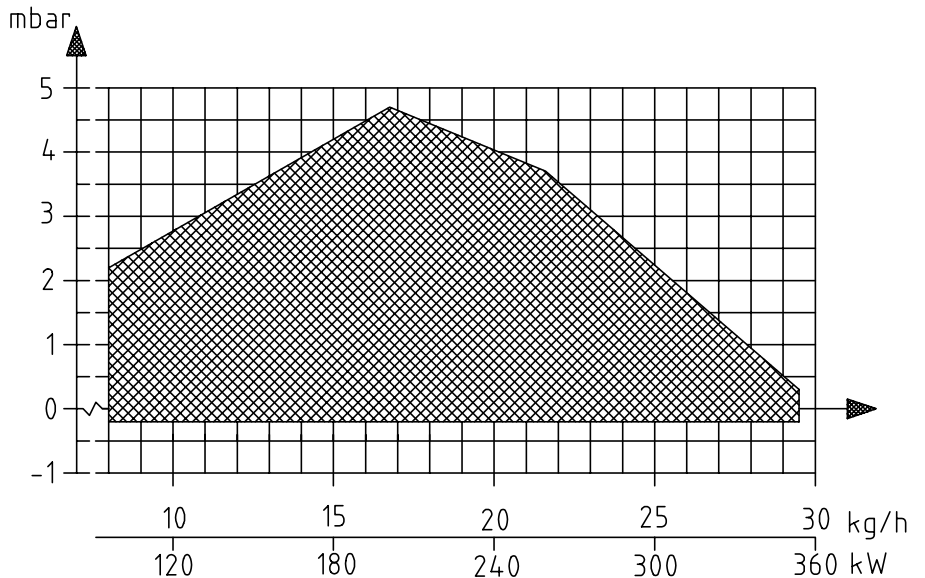
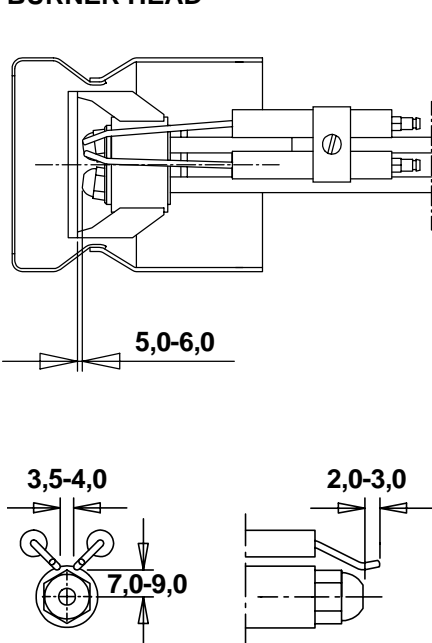

GENERAL INSTRUCTIONS

GENERAL RULES

The installation of an oil burner should be carried out in accordance with local regulations. The installer of the burner must therefore be aware of all regulations relating to oil and combustion.

Only oil suitable for the burner should be used and then in combination with a suitable oil filter before the oil pump of the burner.

If the burner is replacing an existing burner make sure that the oil filter is replaced or cleaned. The installation must only be undertaken by experienced personnel.

INSTALLATION INSTRUCTIONS

General installation instructions accompany the burner and should be left in a prominent place adjacent to the burner.

ADJUSTMENT OF BURNER

The burner is from the factory pre-set to an average value that must then be adjusted to the boiler in question.

All burner adjustments must be made in accordance with boiler manufacturers instructions. These must include the checking of flue gas temperatures, average water temperature and CO₂ or O₂ concentration.

To adjust the combustion device, start by increasing the air volume and the nozzle assembly somewhat. When the burner starts it is burning with excess air and smoke number 0. Reduce the nozzle assembly adjustment until soot occurs, and then increase the adjustment to make the soot disappear again. Then the volume of air is reduced until soot occurs and increased again to reach a combustion free of soot.

By this procedure an optimum adjustment is obtained. If larger nozzles are used the preadjustment of both the air volume and the nozzle assembly must be increased.

A whistling sound may be heard which can be eliminated or reduced as follows: Increase the nozzle assembly adjustment somewhat. The CO₂-content and consequently the air volume

will then be reduced.

CONDENSATION IN CHIMNEY

A modern burner works with less excess air and often also with smaller nozzles than older models. This increases the efficiency but also the risk of condensation in the chimney. The risk increases if the area of the chimney flue is too large. The temperature of the flue gases should exceed 60°C measured 0,5 metres from the chimney top.

Measures to raise the temperature:

Insulate the chimney in cold attics

Install a tube in the chimney

Install a draught regulator (dilutes the flue gases during operation and dries them up during standstill)

Increase the oil quantity

Raise the flue gas temperature by removing turbulators, if any, in the boiler.

PUMP ADJUSTMENT

See separate description.

MAINTENANCE

The boiler/burner should be examined regularly for any signs of malfunction or oil leakage.

OIL SUPPLY

The oil line should be dimensioned in accordance with the pump manufacturer's instruction. In the suction line to the burner a filter should be mounted to prevent any particles in the oil from reaching the burner. If the installation consists of several burners each one should have its own suction line from the tank or a circulation system should be used.

The temperature in the oil line should be kept as constant as possible. Avoid exposing the line to excessive cold which may cause blockages of paraffin deposits.

The oil pipe and electric cable should be fitted so that the burner can be placed on the floor for inspection of the combustion device.

GENERAL INSTRUCTIONS

ADJUSTMENT OF NOZZLE ASSEMBLY

Adjust the nozzle assembly with the adjustment screw D to the desired position.

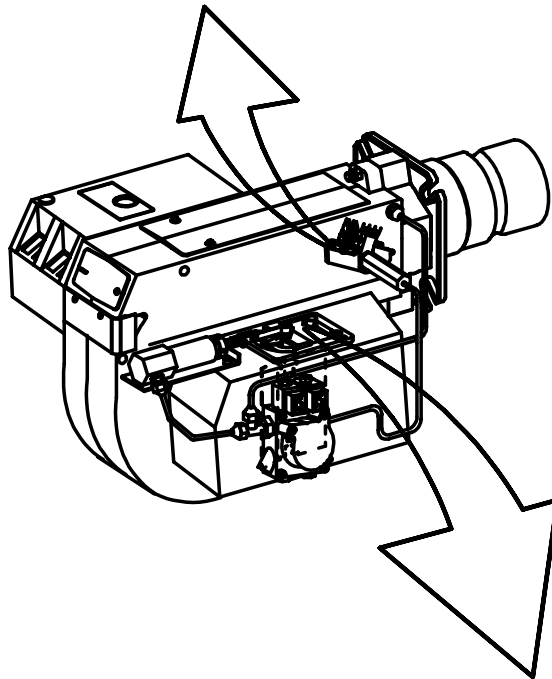
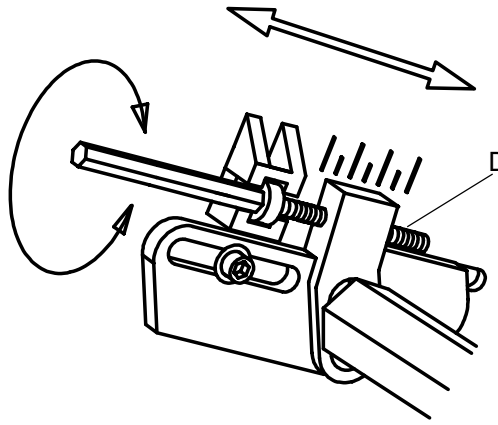

AIR ADJUSTMENT

First stage:

Set the operating switch (S2) on low capacity (I). Loosen the screw (A) and turn the damper to the position wanted. Tighten the screw (A) again.

Second stage:

Set the operating switch (S2) on high capacity (II). Screw the knurled ring (B) in (reduce) or out (increase). The position of the damper can be read on the damper scale (C).

Check the air adjustment by making a flue gas analysis.

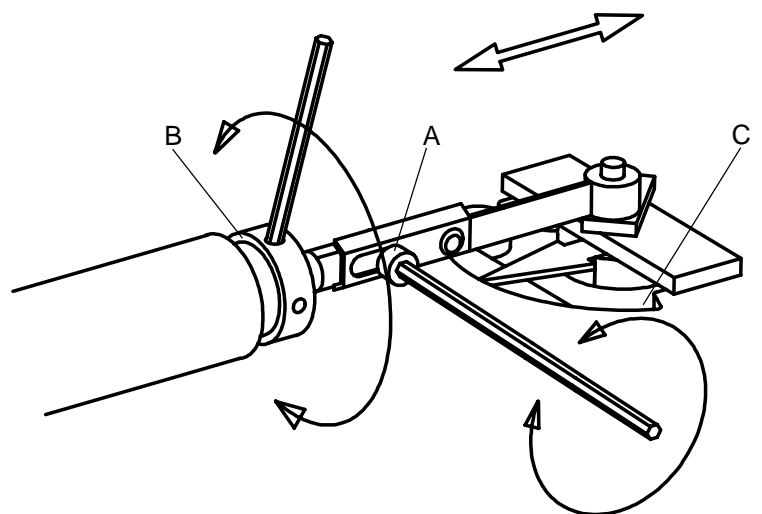

MAINTENANCE

Warning: Before doing any service switch off power at the main switch and cut off the oil supply.

SERVICE OF BURNER HEAD

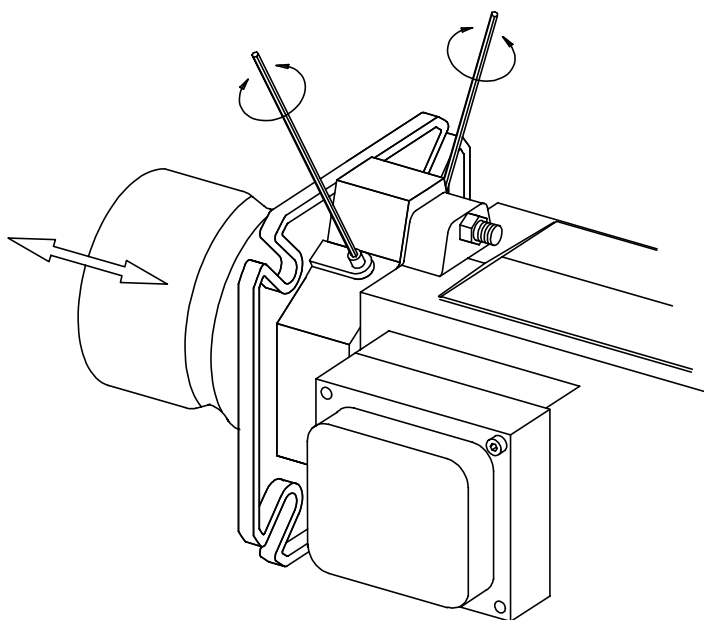
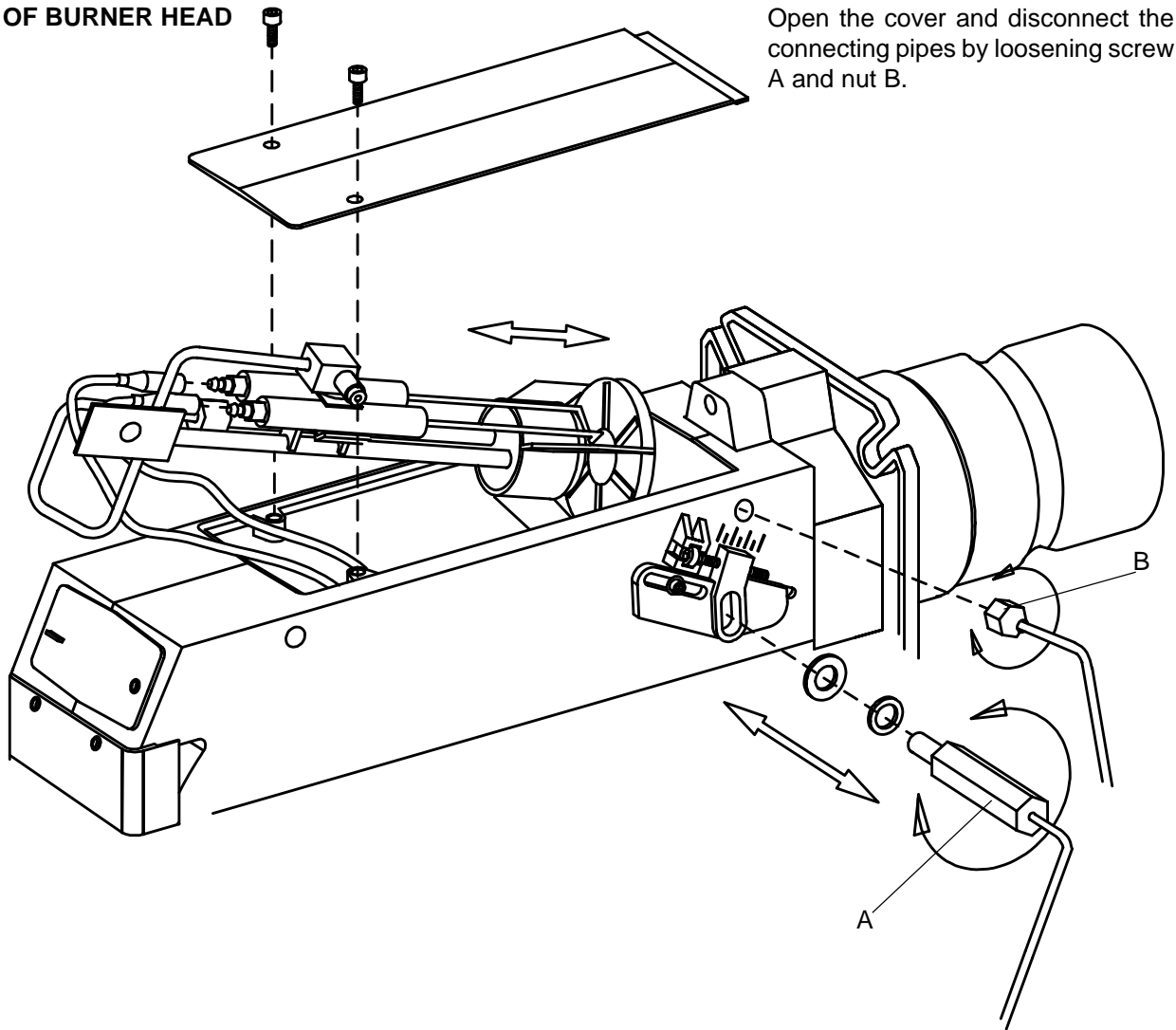

1. Loosen or swing out the burner from the boiler.
2. Loosen 2 fixing screws and withdraw the blast tube.

WIRING DIAGRAM

OIL BURNER CONTROL: LOA21.173A27/LOA24.173A27/BHO61.A/B

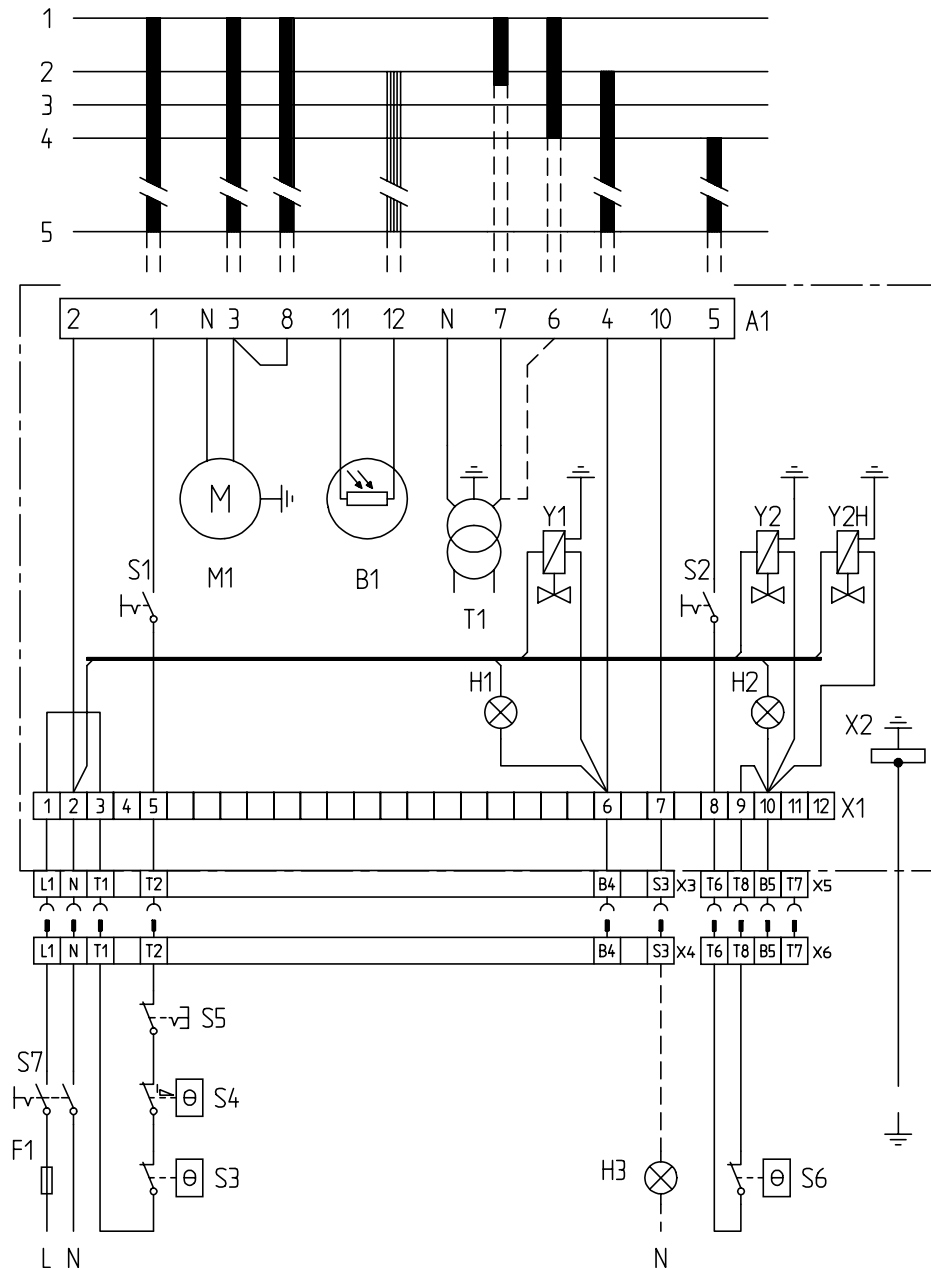

LIST OF COMPONENTS

- A1 Oil burner control
- B1 Photoresistor
- F1 Fuse
- H1 Lamp, low capacity
- H2 Lamp, high capacity
- H3 Lamp, lock-out signal 220 V
- M1 Burner motor
- S1 Operating switch
- S2 Operating switch, high/low capacity
- S3 Control thermostat
- S4 Temperature limiter
- S5 Micro switch for hinged door
- S6 Control thermostat, high/low capacity
- S7 Main switch
- T1 Ignition transformer
- X1 Connection terminal board
- X2 Earth terminal
- X3 Plug-in contact "Euro", burner
- X4 Plug-in contact "Euro", boiler
- X5 Plug-in contact "Euro", high/low burner
- X6 Plug-in contact "Euro", high/low boiler
- Y1 Solenoid valve 1
- Y2 Solenoid valve 2
- Y2H Solenoid valve, Hydraulic piston
(Only 2-stage burners with 1 nozzle.)

If S6 is missing connection between T6 and T8.

Mains connection and fuse in accordance with local regulations.

ELECTRIC EQUIPMENT

OIL BURNER CONTROL: LOA21.173A27/LOA24.173A27/BHO61.A/B

FUNCTION

1. Switch on operating switch and twin thermostat
The burner motor starts, an ignition spark is formed, the prepurge goes on till the prepurge period expires and the solenoid valve 1 opens (2).
2. Solenoid valve 1 opens
Oil mist is formed and ignited. The photocell indicates a flame.
3. The safety time expires
 - a. If no flame is established before this time limit the control cuts out.
 - b. If for some reasons the flame disappears after this time limit, the burner will make an attempt to re-start.
4. Full load thermostat ON
The ignition spark goes out 2 s after flame indication when the ignition transformer is connected to terminal 7. The burner is in operating position and can now change between high and low capacity.
- 4-5. Operating position
If the burner operation is interrupted by means of the main switch or the thermostat, a new start takes place when the conditions in accordance with point 1 are fulfilled.

The oil burner control cuts out

A red lamp in the control is lit. Press the reset button and the burner re-starts.

Post-ignition

If a post-ignition of 15 s is wanted, move the ignition transformer from terminal 7 to terminal 6.

TECHNICAL DATA

Pre-ignition time:	13 s
Pre-purge time:	13 s
Post-ignition time:	2 s
Safety lock-out time:	10 s
Reset time after lockout:	min. 50 s
Reaction time on flame failure:	max. 1 s
Ambient temperature:	from - 20 to +60°C
Min. current with flame established:	65 μ A
Max. photo current at start:	5 μ A
Enclosure:	IP 40

(Under voltage proof only LOA24.173A27)

CONTROL OF PHOTO CURRENT

Current through photo unit is measured with a d.c. ammeter (a moving coil instrument connected in series with the photo unit).

INSTRUCTIONS PUMP TYPE SUNTEC A2L 65C - 75C

TECHNICAL DATA

One or two-pipe system.

Viscosity range: 2-12 mm²/S

Pressure range: 8-15 bar

Rated voltage of coil: 220/240V

50/60 Hz

Oil temperature: max 60°C

COMPONENTS

1. Nozzle outlet G 1/8"
Stage 2
2. Pressure gauge port G 1/8"
3. Nozzle outlet G 1/8"
Stage 1
4. Pressure gauge port G 1/8"
5. Vacuum gauge port G 1/8"
6. Return line G 1/4"
and internal by-pass plug
7. Suction line G 1/4"
8. Return plug
9. Pressure adjustment

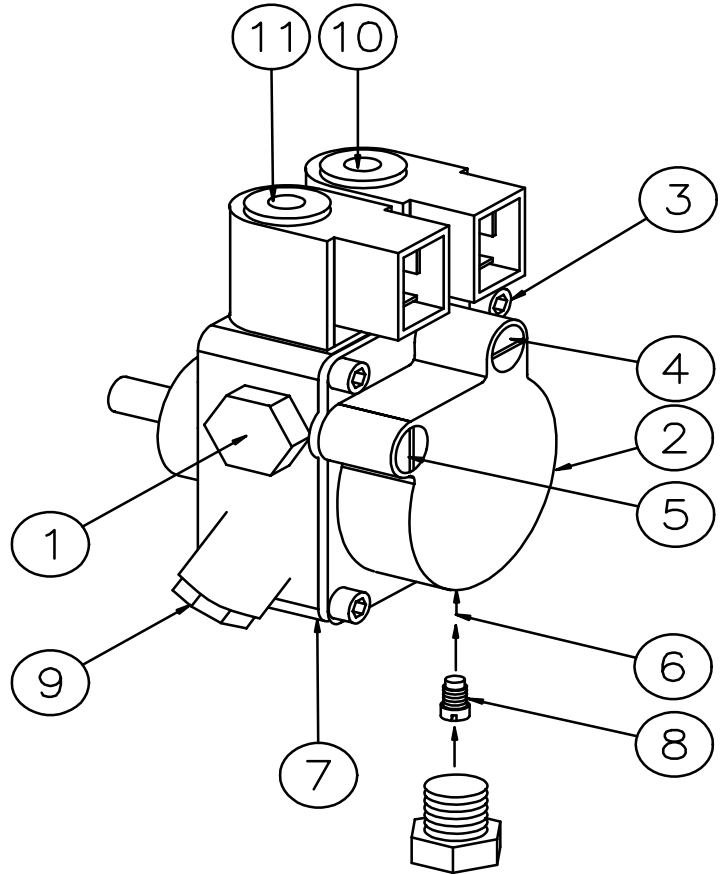

SUCTION LINE TABLES

The suction line tables consist of theoretically calculated values where the pipe dimensions and oil velocity have been matched so that turbulences will not occur. Such turbulences will result in increased pressure losses and in acoustic noise in the pipe system. In addition to drawn copper piping a pipe system usually comprises 4 elbows, a non-return valve, a cut-off valve and an external oil filter.

The sum of these individual resistances is so insignificant that they can be disregarded. The tables do not include any lengths exceeding 100 m as experience shows that longer lengths are not needed.

The tables apply to a standard fuel oil of normal commercial quality according to current standards. On commissioning with an empty tube system the oil pump should not be run without oil for more than 5 min. (a condition is that the pump is being lubricated during operation).

The tables state the total suction line length in metres at a nozzle capacity of 9,5 Gph. Max. permissible pressure at the suction and pressure side is 2,0 bar.

<p>1-pipe system</p> <table border="1"> <thead> <tr> <th rowspan="2">Height H</th> <th colspan="3">Pipe diameter</th> </tr> <tr> <th>ø6 mm</th> <th>ø8 mm</th> <th>ø10 mm</th> </tr> </thead> <tbody> <tr> <td>m</td> <td>m</td> <td>m</td> <td>m</td> </tr> <tr> <td>4,0</td> <td>45</td> <td>144</td> <td>150</td> </tr> <tr> <td>3,0</td> <td>39</td> <td>127</td> <td>150</td> </tr> <tr> <td>2,0</td> <td>34</td> <td>109</td> <td>150</td> </tr> <tr> <td>1,0</td> <td>28</td> <td>92</td> <td>150</td> </tr> <tr> <td>0,5</td> <td>26</td> <td>83</td> <td>150</td> </tr> <tr> <td>0,0</td> <td>23</td> <td>74</td> <td>150</td> </tr> </tbody> </table>		Height H	Pipe diameter			ø6 mm	ø8 mm	ø10 mm	m	m	m	m	4,0	45	144	150	3,0	39	127	150	2,0	34	109	150	1,0	28	92	150	0,5	26	83	150	0,0	23	74	150	<p>1-pipe system</p> <table border="1"> <thead> <tr> <th rowspan="2">Height H</th> <th>Pipe diameter</th> </tr> <tr> <th>ø6 mm</th> </tr> </thead> <tbody> <tr> <td>m</td> <td>m</td> </tr> </tbody> </table> <p>With an underlying tank a 1-pipe-system is not recommended</p>		Height H	Pipe diameter	ø6 mm	m	m																																																
Height H	Pipe diameter																																																																																										
	ø6 mm	ø8 mm	ø10 mm																																																																																								
m	m	m	m																																																																																								
4,0	45	144	150																																																																																								
3,0	39	127	150																																																																																								
2,0	34	109	150																																																																																								
1,0	28	92	150																																																																																								
0,5	26	83	150																																																																																								
0,0	23	74	150																																																																																								
Height H	Pipe diameter																																																																																										
	ø6 mm																																																																																										
m	m																																																																																										
<p>Two-pipe system</p> <table border="1"> <thead> <tr> <th rowspan="2">Height H</th> <th colspan="4">Pipe diameter</th> </tr> <tr> <th>ø8mm</th> <th>ø10mm</th> <th>ø12mm</th> <th>ø14mm</th> </tr> </thead> <tbody> <tr> <td>m</td> <td>m</td> <td>m</td> <td>m</td> <td>m</td> </tr> <tr> <td>4,0</td> <td>42</td> <td>108</td> <td>150</td> <td>150</td> </tr> <tr> <td>3,0</td> <td>36</td> <td>94</td> <td>150</td> <td>150</td> </tr> <tr> <td>2,0</td> <td>31</td> <td>81</td> <td>150</td> <td>150</td> </tr> <tr> <td>1,0</td> <td>26</td> <td>68</td> <td>144</td> <td>150</td> </tr> <tr> <td>0,5</td> <td>23</td> <td>61</td> <td>130</td> <td>150</td> </tr> <tr> <td>0,0</td> <td>20</td> <td>54</td> <td>116</td> <td>150</td> </tr> </tbody> </table>		Height H	Pipe diameter				ø8mm	ø10mm	ø12mm	ø14mm	m	m	m	m	m	4,0	42	108	150	150	3,0	36	94	150	150	2,0	31	81	150	150	1,0	26	68	144	150	0,5	23	61	130	150	0,0	20	54	116	150	<p>Two-pipe system</p> <table border="1"> <thead> <tr> <th rowspan="2">Height H</th> <th colspan="4">Pipe diameter</th> </tr> <tr> <th>ø8mm</th> <th>ø10mm</th> <th>ø12mm</th> <th>ø14mm</th> </tr> </thead> <tbody> <tr> <td>m</td> <td>m</td> <td>m</td> <td>m</td> <td>m</td> </tr> <tr> <td>0,0</td> <td>20</td> <td>54</td> <td>116</td> <td>150</td> </tr> <tr> <td>-0,5</td> <td>17</td> <td>48</td> <td>103</td> <td>150</td> </tr> <tr> <td>-1,0</td> <td>15</td> <td>41</td> <td>89</td> <td>150</td> </tr> <tr> <td>-2,0</td> <td>9</td> <td>28</td> <td>61</td> <td>116</td> </tr> <tr> <td>-3,0</td> <td>4</td> <td>14</td> <td>33</td> <td>65</td> </tr> <tr> <td>-4,0</td> <td>0</td> <td>0</td> <td>6</td> <td>14</td> </tr> </tbody> </table>		Height H	Pipe diameter				ø8mm	ø10mm	ø12mm	ø14mm	m	m	m	m	m	0,0	20	54	116	150	-0,5	17	48	103	150	-1,0	15	41	89	150	-2,0	9	28	61	116	-3,0	4	14	33	65	-4,0	0	0	6	14
Height H	Pipe diameter																																																																																										
	ø8mm	ø10mm	ø12mm	ø14mm																																																																																							
m	m	m	m	m																																																																																							
4,0	42	108	150	150																																																																																							
3,0	36	94	150	150																																																																																							
2,0	31	81	150	150																																																																																							
1,0	26	68	144	150																																																																																							
0,5	23	61	130	150																																																																																							
0,0	20	54	116	150																																																																																							
Height H	Pipe diameter																																																																																										
	ø8mm	ø10mm	ø12mm	ø14mm																																																																																							
m	m	m	m	m																																																																																							
0,0	20	54	116	150																																																																																							
-0,5	17	48	103	150																																																																																							
-1,0	15	41	89	150																																																																																							
-2,0	9	28	61	116																																																																																							
-3,0	4	14	33	65																																																																																							
-4,0	0	0	6	14																																																																																							

PUMP OPERATING PRINCIPLE FOR A2L 65C - 75C

The **SUNTEC A2L** oil pump has two nozzle outlets. It incorporates two blocking solenoid valves with in-line-cut-off function, one for each nozzle outlet.

The gear set draws oil from the tank through the built-in filter and transfers it to the nozzle line via the cut-off solenoid valves. A pressure regulating valve is used to dump all oil which is not required at the nozzle.

In one-pipe operation, the oil which does not go through the nozzle lines is returned directly to the gear inlet and the suction line flow is equal to the sum of the 2 nozzle flows. In two-pipe operation, the by-pass plug must be fitted in the return port, which ensures that the oil dumped by the regulating valve is returned to the tank and the suction line flow is equal to the gear set capacity.

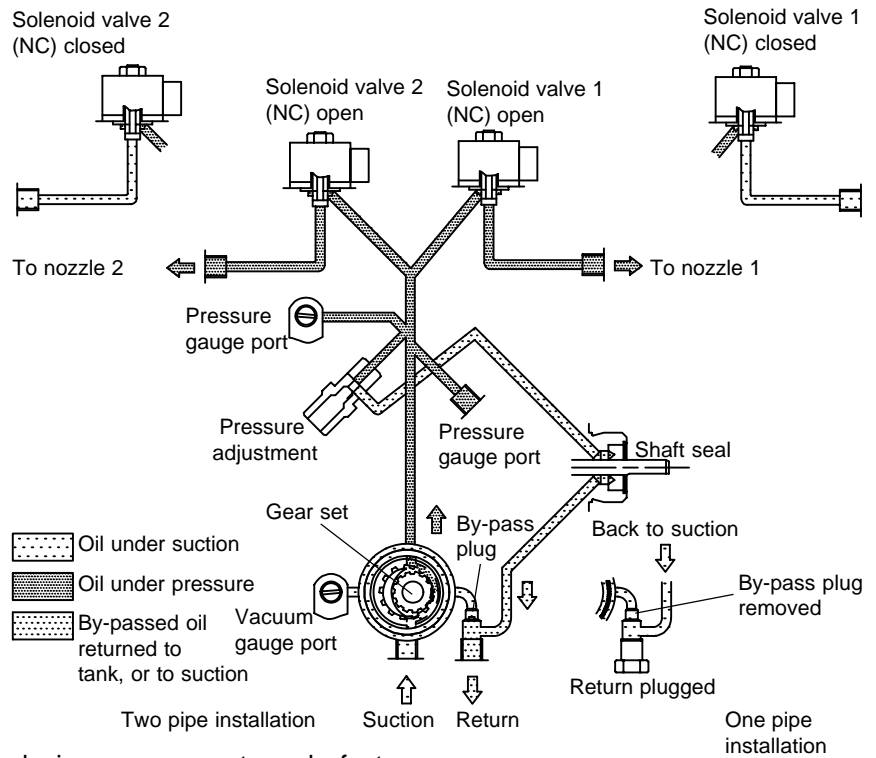

design ensures extremely fast response and the switching can be selected according to the burner operating sequence and is independent of motor speed.

When the solenoids are non-activated, the valves are closed and all oil pressurised by the gear set passes through the regulator to suction or to the return line, depending upon pipe arrangement.

As soon as the solenoids are activated, oil passes to the nozzle lines at the pressure set by the pressure regulating valve.

Shaft rotation and nozzle location seen from shaft end

Gear set capacity

A2L: 2 nozzle outlets

A2LXX C

BLEED

Bleeding in two-pipe operation is automatic: it is assured by a bleed flat on the piston. In one-pipe operation, a high pressure connection must be loosened until the air is evacuated from the system.

CUT-OFF

The solenoid valves of the A2L pump are of the "normally closed" type and are situated in the nozzle lines. This

EXCHANGE OF FILTER

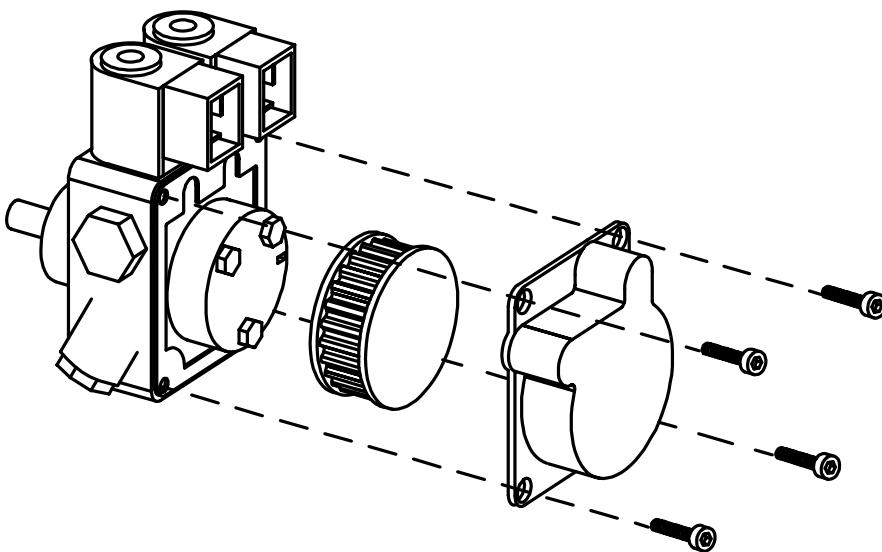

MOUNTING/DISMOUNTING RETURN PLUG

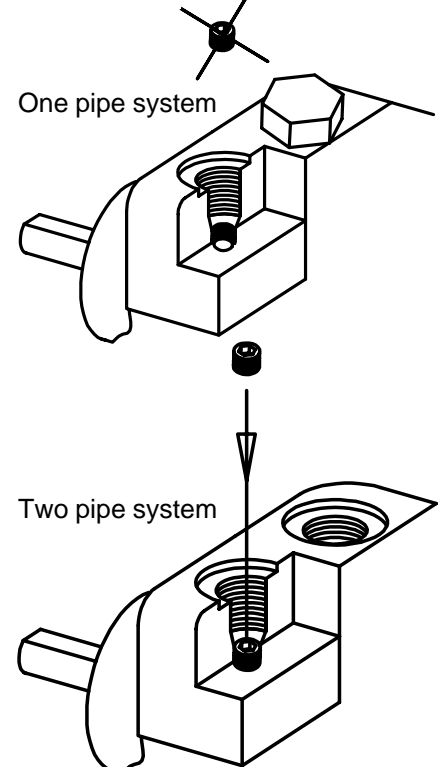

NOZZLE TABLE

Pump pressure bar

Gph	8			9			10			11			12			13			14			15		
	kg/h	kW	Mcal/h	kg/h	kW	Mcal/h	kg/h	kW	Mcal/h	kg/h	kW	Mcal/h	kg/h	kW	Mcal/h	kg/h	kW	Mcal/h	kg/h	kW	Mcal/h	kg/h	kW	Mcal/h
0,40	1,33	16	13	1,41	17	14	1,49	18	15	1,56	18	16	1,63	19	17	1,70	20	17	1,76	21	18	1,82	21	18
0,50	1,66	20	17	1,76	21	18	1,86	22	19	1,95	23	20	2,04	24	21	2,12	25	22	2,20	26	22	2,28	27	23
0,60	2,00	24	20	2,12	25	22	2,23	26	23	2,34	28	24	2,45	29	25	2,55	30	26	2,64	31	27	2,73	32	28
0,65	2,16	26	22	2,29	27	23	2,42	29	25	2,54	30	26	2,65	31	27	2,75	33	28	2,86	34	29	2,96	35	30
0,75	2,49	29	25	2,65	31	27	2,79	33	28	2,93	35	30	3,08	36	31	3,18	38	32	3,30	39	34	3,42	40	35
0,85	2,83	33	29	3,00	36	31	3,16	37	32	3,32	39	34	3,47	41	35	3,61	43	37	3,74	44	38	3,87	46	39
1,00	3,33	39	34	3,53	42	36	3,72	44	38	3,90	46	40	4,08	48	42	4,24	50	43	4,40	52	45	4,56	54	46
1,10	3,66	43	37	3,88	46	39	4,09	48	42	4,29	51	44	4,48	53	46	4,67	55	48	4,84	57	49	5,01	59	51
1,20	3,99	47	41	4,24	50	43	4,47	53	46	4,68	55	48	4,89	58	50	5,09	60	52	5,29	63	54	5,47	65	56
1,25	4,16	49	42	4,40	52	45	4,65	55	47	4,88	58	50	5,10	60	52	5,30	63	54	5,51	65	56	5,70	68	58
1,35	4,49	53	46	4,76	56	48	5,02	59	51	5,27	62	54	5,50	65	56	5,73	68	58	5,95	70	61	6,15	73	63
1,50	4,98	59	51	5,29	63	54	5,58	66	57	5,85	69	60	6,11	72	62	6,36	75	65	6,60	78	67	6,83	81	70
1,65	5,49	65	56	5,82	69	59	6,14	73	63	6,44	76	66	6,73	80	69	7,00	83	71	7,27	86	74	7,52	89	77
1,75	5,82	69	59	6,18	73	63	6,51	77	66	6,83	81	70	7,14	85	73	7,42	88	76	7,71	91	79	7,97	94	81
2,00	6,65	79	68	7,06	84	72	7,45	88	76	7,81	93	80	8,18	97	83	8,49	101	86	8,81	104	90	9,12	108	93
2,25	7,49	89	76	7,94	94	81	8,38	99	85	8,78	104	89	9,18	109	94	9,55	113	97	9,91	117	101	10,26	122	105
2,50	8,32	99	85	8,82	105	90	9,31	110	95	9,76	116	99	10,19	121	104	10,61	126	108	11,01	130	112	11,39	135	116
2,75	9,15	108	93	9,71	115	99	10,24	121	104	10,73	127	109	11,21	133	114	11,67	138	119	12,11	144	123	12,53	148	128
3,00	9,98	118	102	10,59	126	108	11,16	132	114	11,71	139	119	12,23	145	125	12,73	151	130	13,21	157	135	13,67	162	139
3,50	11,65	138	119	12,35	146	126	13,03	154	133	13,66	162	139	14,27	169	145	14,85	176	151	15,42	183	157	15,95	189	163
4,00	13,31	158	136	14,12	167	144	14,89	176	152	15,62	185	159	16,31	193	166	16,97	201	173	17,62	209	180	18,23	216	186
4,50	14,97	177	153	15,88	188	162	16,75	198	171	17,57	208	179	18,35	217	187	19,10	226	195	19,82	235	202	20,51	243	209
5,00	16,64	197	170	17,65	209	180	18,62	221	190	19,52	231	199	20,39	242	208	21,22	251	216	22,03	261	225	22,79	270	232
5,50	18,30	217	187	19,42	230	198	20,48	243	209	21,47	255	219	22,43	266	229	23,34	277	238	24,23	287	247	25,07	297	256
6,00	19,97	237	204	21,18	251	216	22,34	265	228	23,42	278	239	24,47	290	249	25,46	302	260	26,43	313	269	27,49	326	280
6,50	21,63	256	220	22,94	272	234	24,20	287	247	25,37	301	259	26,51	314	270	27,58	327	281	28,63	339	292	29,63	351	302
7,00	23,29	276	237	24,71	293	252	26,06	309	266	27,33	324	279	28,55	338	291	29,70	352	303	30,84	366	314	31,91	378	325
7,50	24,96	296	254	26,47	314	270	27,92	331	285	29,28	347	298	30,59	363	312	31,83	377	324	33,04	392	337	34,19	405	349
8,00	26,62	316	271	28,24	335	288	29,79	353	304	31,23	370	318	32,63	387	333	33,95	403	346	35,25	418	359	36,47	432	372
8,50	28,28	335	288	30,00	356	306	31,65	375	323	33,18	393	338	34,66	411	353	36,07	428	368	37,45	444	382	38,74	459	395
9,00	29,95	355	305	31,77	377	324	33,59	398	342	35,14	417	358	36,71	435	374	38,19	453	389	39,65	470	404	41,02	486	418

 The table applies to oil with a viscosity of 4,4 mm²/s (cSt) with density 830 kg/m³.

BURNER WITH PREHEATER

Consider that on preheating the oil quantity is reduced by 5-20% depending on.

- Rise in temperature at the nozzle
- Design of nozzle
- Capacity (high capacity - small difference)

FAULT LOCATION

BURNER FAILS TO START

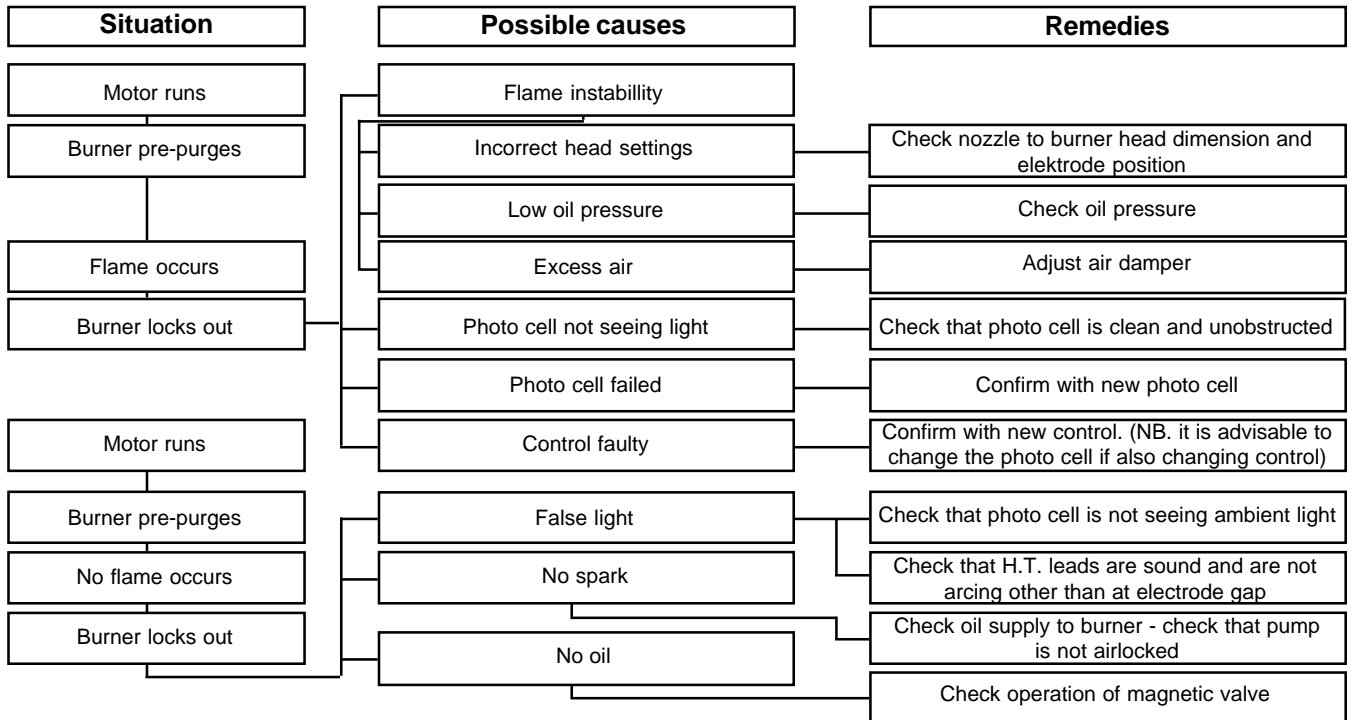

BURNER FAILS TO START AFTER NORMAL OPERATION

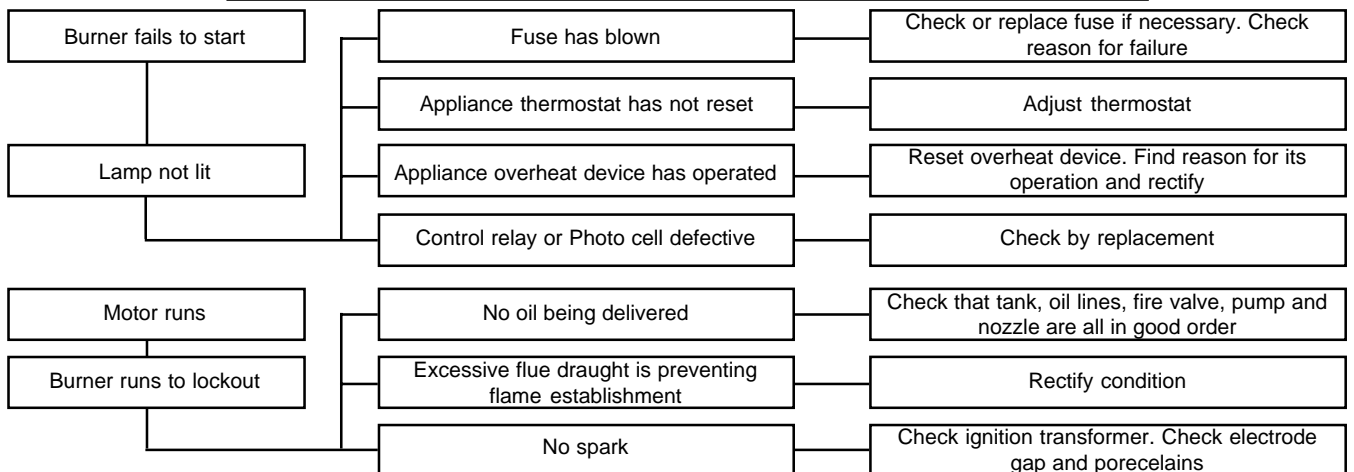

DELAYED IGNITION, BURNERS STARTS VIOLENTLY

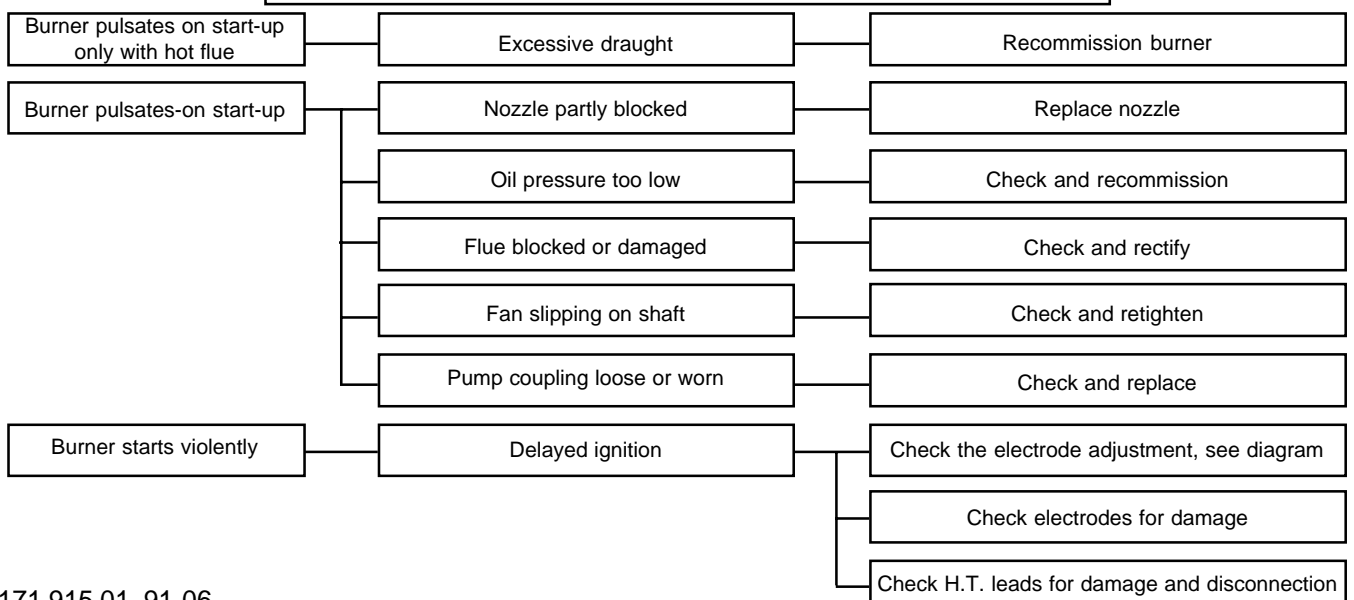

DECLARATION OF CONFORMITY

We
(supplier's name)

BENTONE AB

(address)

P.O. Box 309, S-341 26 Ljungby, Sverige

declare under our sole responsibility that the product
(name, type or model, batch or serial number, possibly sources and number of items)

ST 97, ST 108, ST 120, ST 133, ST 146, B 9, B 10, B 11, B 20, B 30, B 40, B 45, B 50, B 60, B 70, B 80, SF 141

and TF 205, fan burners for gasoil

to which this declaration relates is in conformity with the following standard(s) or the normative document(s)
(title and/or number and date of issue of the standard(s) or other normative document(s))

DIN 4787 and EN 267

following the provisions of Directive
(if applicable)

EMC directive 89 / 336 / EEC, Low voltage directive 73 / 23 / EEC and Machinery directive 89/392/EEC.

Re. the Efficiency directive 92/42/EEC, please see the next page.

Ljungby, 25th May, 1999

(Place and date of issue)

BENTONE AB

Ulf Bondeson



(name and signature of equivalent marking of authorized person)

To fulfil the demands according to the Efficiency directive 92/42/EEC, Article 2, we herewith state the following parameters.

Burner type	Capacity kg/h (kW)	Test report No. TÜV	Pressure in combustion chamber mbar	Product ID-No. as per EC-Type Examination Certificate
ST 97	1,2-2,6 (14,2-30,8)	3728 (15.03.96)	-0,2 to+1,4 to + 0,1	CE 0036 0128/98
ST 108	1,2-3,8 (14,2-45)	3729 (15.03.96)	-0,2 to + 1,4 to + 0,2	CE 0036 0129/98
ST 120	2,1-4,5 (24,9-53,3)	3581 (10.11.94)	-0,2 to + 1,9 to + 0,2	CE 0036 0130/98
ST 133	2,0-10,0 (23,7-118,5)	3795 (12.11.96)	-0,2 to + 2,2 to + 0,1	CE 0036 0131/98
ST 146	4,0-10,0 (47,4-118,5)	3796 (12.11.96)	-0,2 to + 3,9 to + 0,1	CE 0036 0132/98
B 9	1,2-2,5 (14,2-29,6)	3341 (21.08.92)	-0,2 to + 0,8 to + 0,1	CE 0036 0133/98
B 10	1,4-3,0 (16,6-35,6)	3465 (03.09.93)	-0,2 to + 1,1 to + 0,25	CE 0036 0134/98
B 10KA	2,0-4,6 (23,7-54,5)	3778 (18.10.96)	-0,2 to + 0,95 to + 0,1	CE 0036 0135/98
B 10ZHV	1,2-2,5 (14,2-29,5)	3525 (21.01.94)	-0,2 to + 1,0 to + 0,3	CE 0036 0136/98
B 11				
B 20K	4,3-9,8 (51,0-116,1)	3779 (18.10.96)	-0,2 to + 1,15 to + 0,1	CE 0036 0137/98
B 20KA	2,0-8,0 (23,7-94,8)	3333 (04.08.92)	-0,2 to 0,78 to + 0,1	CE 0036 0138/98
B 20ZHV	2,1-4,3 (24,9-51,0)	3397 (14-06.93)	-0,2 to 1,25 to + 0,1	CE 0036 0139/98
B 30	6,0-17,5 (71,1-207,4)	3524 (24.01.94)	-0,2 to + 2,8 to + 0,2	CE 0036 0140/98
B 30A	6,0-17,0 (71,1-207,4)	3797 (12.11.96)	-0,2 to + 3,0 to + 0,1	CE 0036 0141/98
B 30A2	4,5-15,0 (53,3-177,8)	3798 (12.11.96)	-0,2 to 3,8 to + 0,1	CE 0036 0142/98
B 30ZHV-2	3,3-10,0 (39,1-118,5)	3563 (10.11.94)	-0,2 to + 1,3 to + 0,1	CE 0036 0143/98
B 40	9,0-29,5 (106,7-349,6)	3503 (21.09.93)	-0,3 to + 4,1 to + 0,2	CE 0036 0144/98
B 40A	9,0-29,5 (106,7-349,6)	3799 (12.11.96)	-0,2 to + 5,3 to + 0,1	CE 0036 0145/98

To fulfil the demands according to the Efficiency directive 92/42/EEC, Article 2, we herewith state the following parameters.

Burner type	Capacity kg/h (kW)	Test report No. TÜV	Pressure in combustion chamber mbar	Product ID-No. as per EC-Type Examination Certificate
B 50-2F	12,0-59,0 (142,2-699,2)	3390 (09.06.93)	-0,2 to +9,4 to + 0,2	CE 0036 0147/98
B 50-3F	12,0-59,0 (142,2-699,2)	3592 (10.11.94)	-0,2 to + 9,25 to + 0,1	CE 0036 0148/98
B 60-2F	20,0-90,0 (237,0-1066,5)	3466 (03.09.93)	-0,3 to + 11,4 to + 0,8	CE 0036 0149/98
B 60-3F	20,0-90,0 (237,0-1066,5)	3591 (10.11.94)	-0,3 to + 11,4 to + 0,8	CE 0036 0150/98
B 70				
B 80				
SF 141-3	50,0-140,0 (592,5-1659,0)	3502 (16.09.93)	-0,7 to 8,7 to + 12,0 to + 0,1	CE 0036 0151/98
TF 205-3	70,0-205,0	3501 (16.09.93)	-0,7 to + 14,0 to + 16,0 to + 0,1	CE 0036 0152/98
B45A	8,5-47,0 (100,8-557,5)	3977 (16.04.99)	-0,1 to + 0,4 to + 7,0	CE 0036 0250/99
B45A2	8,5-45,5 (100,8-539,7)	3978 (16.04.99)	-0,1 to + 0,4 to + 7,5	CE 0036 0251/99