

B45A2.2H

DESCRIPTION

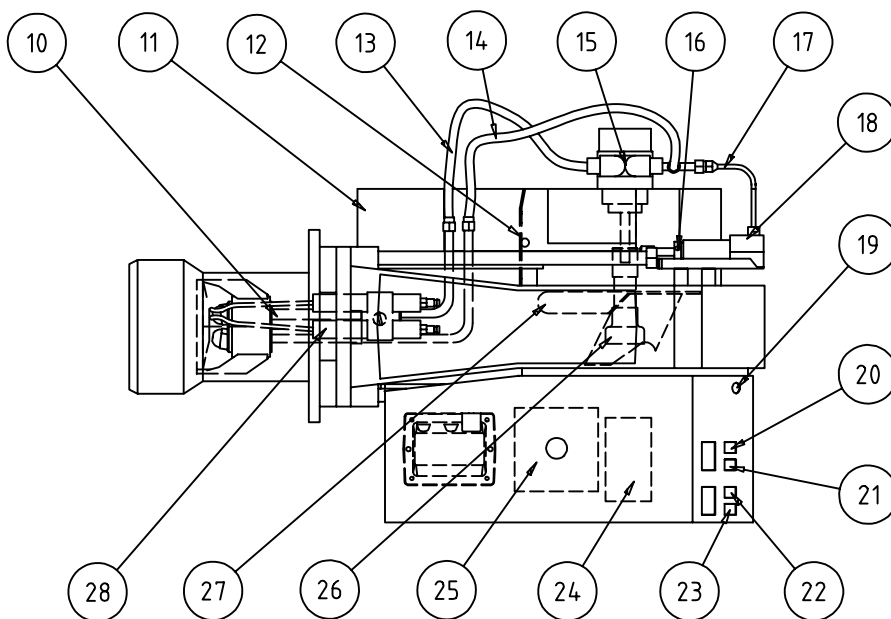
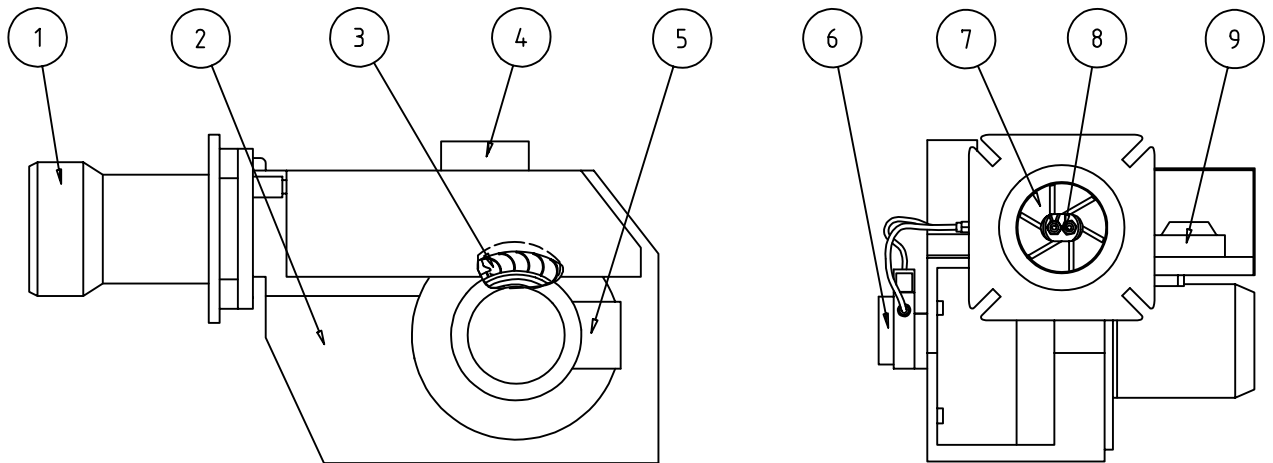

COMPONENTS

- | | | |
|-------------------------|--|-----------------------------|
| 1. Flame cone | 11. Air intake | 19. Fuse |
| 2. Fan housing | 12. Air damper | 20. Indicating lamp Stage 2 |
| 3. Fan wheel | 13. Connecting pipe Stage 1 | 21. Switch I-II |
| 4. Damper motor | 14. Connecting pipe Stage 2 | 22. Indicating lamp Stage 1 |
| 5. Motor | 15. Solenoid valves | 23. Switch 0-I |
| 6. Pump | 16. Nozzle assembly adjustment | 24. Contactor |
| 7. Shrouded disc | 17. Connecting pipe, pump-
adjustment device | 25. Control box |
| 8. Nozzle | 18. Adjustment device, Nozzle
assembly adjustment | 26. Drive coupling |
| 9. Ignition transformer | | 27. Conical shield plate |
| 10. Nozzle assembly | | 28. Ignition electrodes |

TECHNICAL DATA

Type designation B45A2

DIMENSIONS

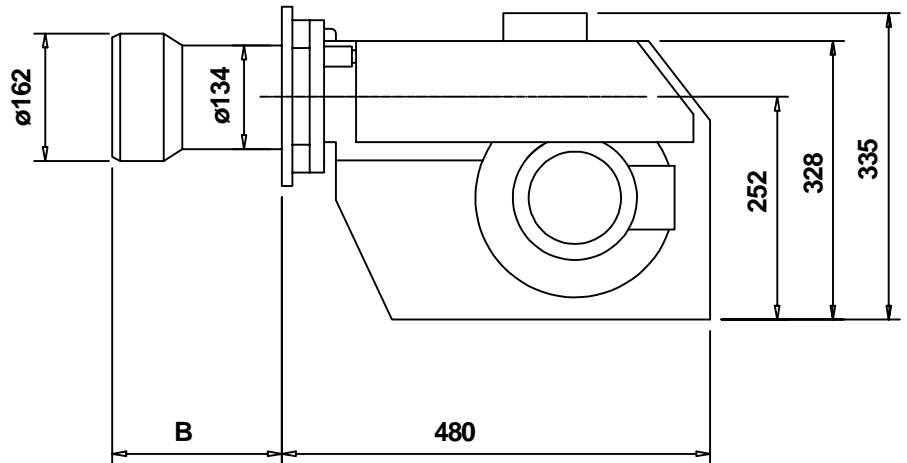
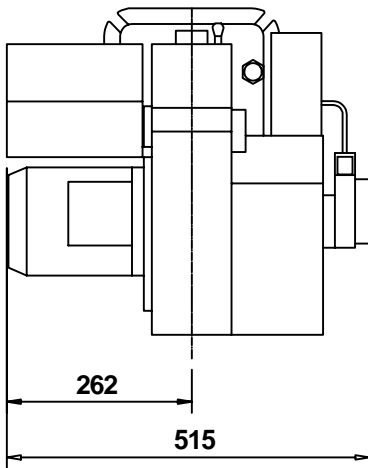

	Length of burner tube	Flange Measure B
B45A2	270	238
B45A2	370	338

OUTPUT RANGE AND NOZZLES RECOMMENDED

	Oil capacity kg/h	Output kW	Output Mcal/h	Recommended nozzle Angle	Danfoss	Monarch	Recommended Pump pressure
B45A2	8,5-45,5	101-540	87-464	45° - 60°	S, B	R, PLP	14 bar

The net calorific value of 11,86 kWh/kg for light oil has been used.

RECOMMENDED NOZZLE

Because of different boiler types existing on the market, with varying combustion chamber designs, it is not possible to

state a definite spray angle or spray pattern.

Note that the spray angle and the spray pattern change with the pump pressure.

BURNER HEAD

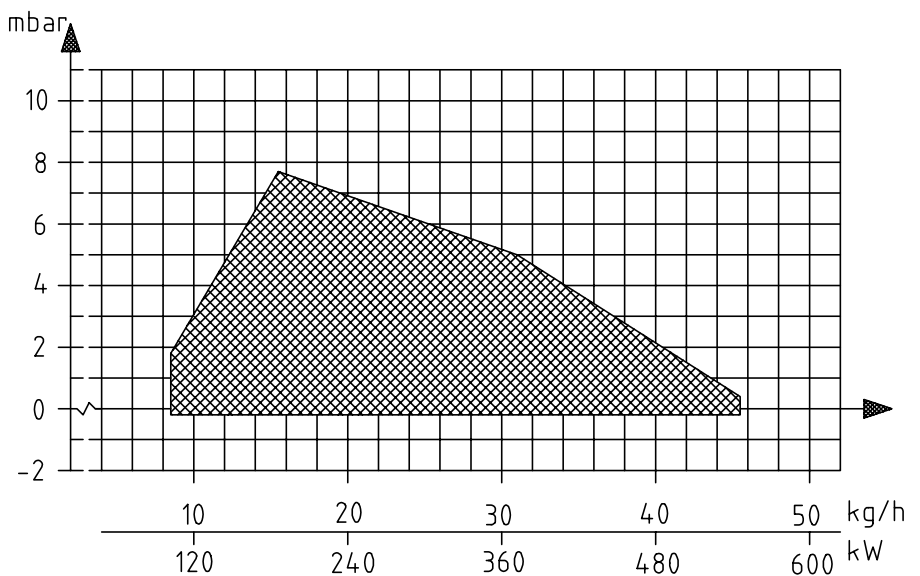
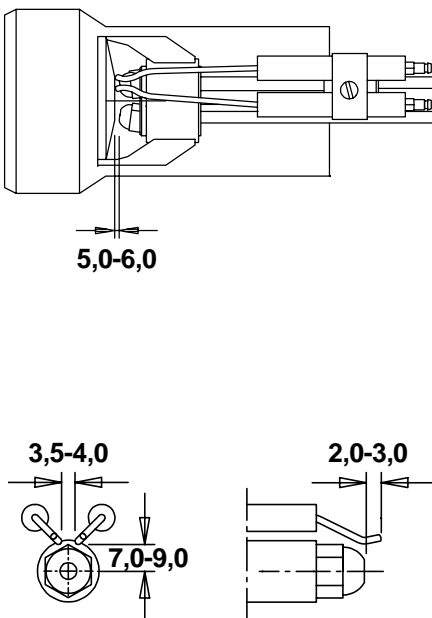

TECHNICAL DATA

DIMENSIONS OF FLANGE

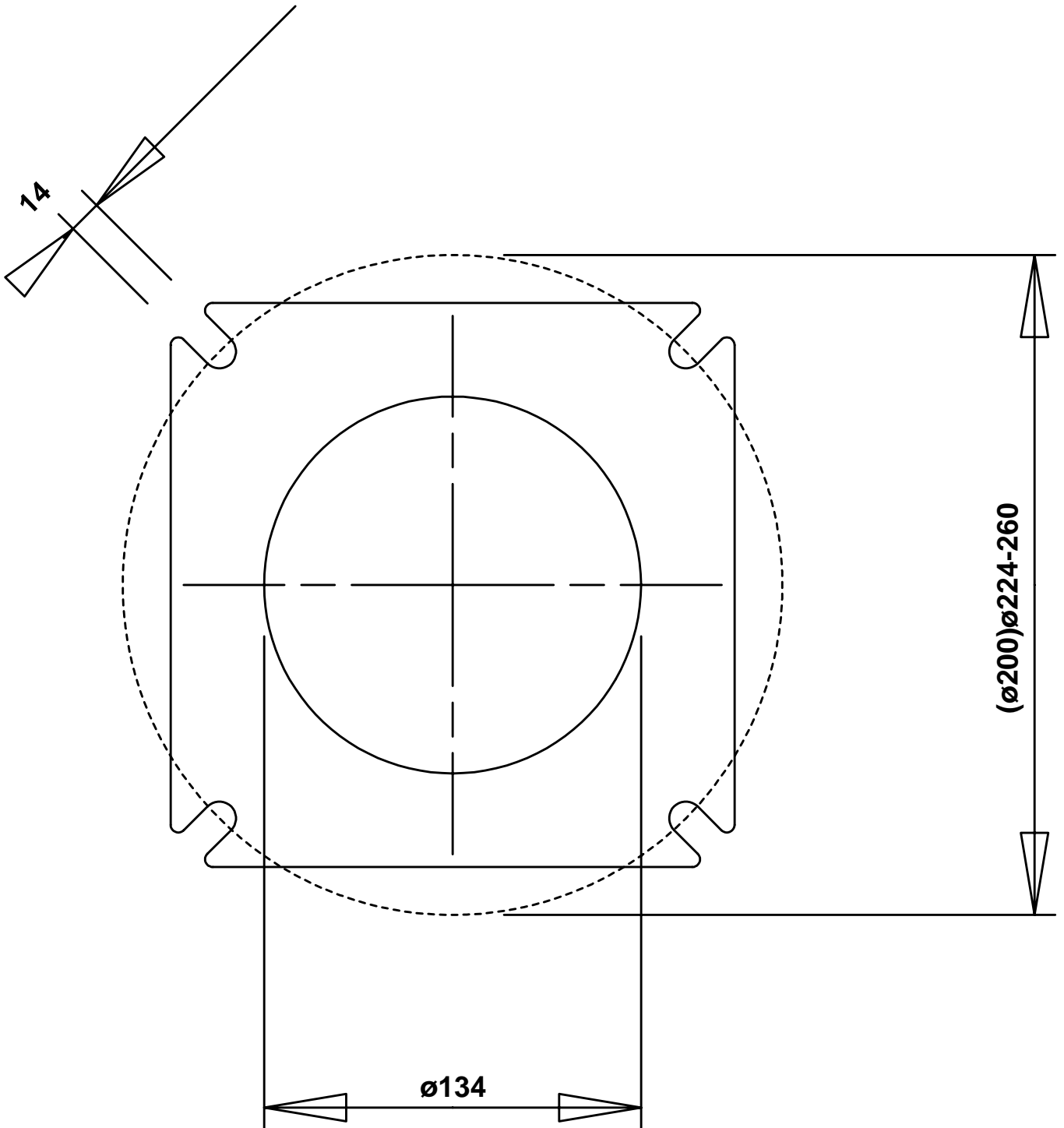

GENERAL INSTRUCTIONS

GENERAL RULES

The installation of an oil burner should be carried out in accordance with local regulations. The installer of the burner must therefore be aware of all regulations relating to oil and combustion.

Only oil suitable for the burner should be used and then in combination with a suitable oil filter before the oil pump of the burner.

If the burner is replacing an existing burner make sure that the oil filter is replaced or cleaned. The installation must only be undertaken by experienced personnel.

INSTALLATION INSTRUCTIONS

General installation instructions accompany the burner and should be left in a prominent place adjacent to the burner.

ADJUSTMENT OF BURNER

The burner is from the factory pre-set to an average value that must then be adjusted to the boiler in question.

All burner adjustments must be made in accordance with boiler manufacturers instructions. These must include the checking of flue gas temperatures, average water temperature and CO₂ or O₂ concentration.

To adjust the combustion device, start by increasing the air volume and the nozzle assembly somewhat. When the burner starts it is burning with excess air and smoke number 0. Reduce the nozzle assembly adjustment until soot occurs, and then increase the adjustment to make the soot disappear again. Then the volume of air is reduced until soot occurs and increased again to reach a combustion free of soot.

By this procedure an optimum adjustment is obtained. If larger nozzles are used the preadjustment of both the air volume and the nozzle assembly must be increased.

A whistling sound may be heard which can be eliminated or reduced as follows: Increase the nozzle assembly adjustment somewhat. The CO₂-content and consequently the air volume

will then be reduced.

CONDENSATION IN CHIMNEY

A modern burner works with less excess air and often also with smaller nozzles than older models. This increases the efficiency but also the risk of condensation in the chimney. The risk increases if the area of the chimney flue is too large. The temperature of the flue gases should exceed 60°C measured 0,5 metres from the chimney top.

Measures to raise the temperature:

Insulate the chimney in cold attics

Install a tube in the chimney

Install a draught regulator (dilutes the flue gases during operation and dries them up during standstill)

Increase the oil quantity

Raise the flue gas temperature by removing turbulators, if any, in the boiler.

PUMP ADJUSTMENT

See separate description.

MAINTENANCE

The boiler/burner should be examined regularly for any signs of malfunction or oil leakage.

OIL SUPPLY

The oil line should be dimensioned in accordance with the pump manufacturer's instruction. In the suction line to the burner a filter should be mounted to prevent any particles in the oil from reaching the burner. If the installation consists of several burners each one should have its own suction line from the tank or a circulation system should be used.

The temperature in the oil line should be kept as constant as possible. Avoid exposing the line to excessive cold which may cause blockages of paraffin deposits.

The oil pipe and electric cable should be fitted so that the burner can be placed on the floor for inspection of the combustion device.

GENERAL INSTRUCTIONS

ADJUSTMENT OF NOZZLE

ASSEMBLY

Adjust the nozzle assembly with the adjustment screw D to the desired position.

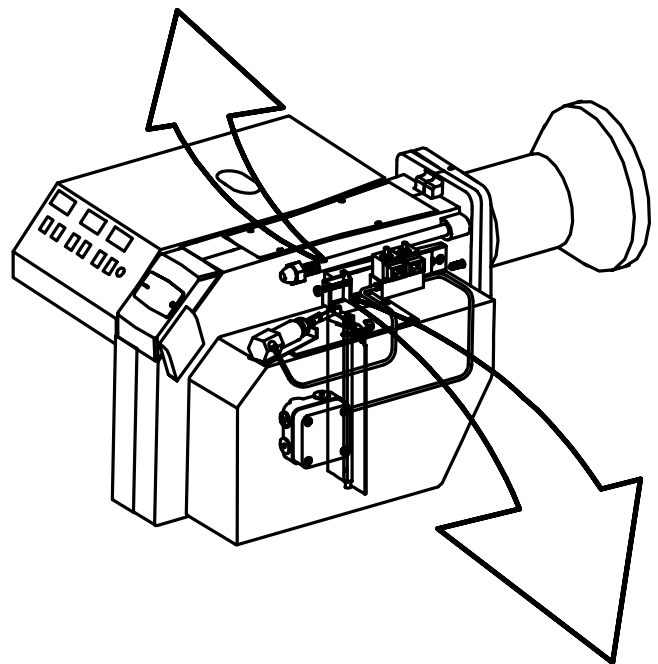
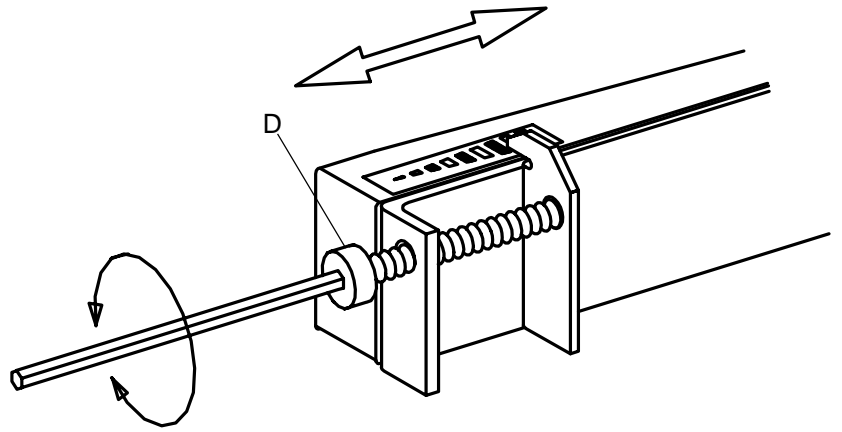

AIR ADJUSTMENT

First stage:

Set the operating switch (S2) on low capacity (I). Loosen the screw (A) and turn the damper to the position wanted. Tighten the screw (A) again.

Second stage:

Set the operating switch (S2) on high capacity (II). Screw the knurled ring (B) in (reduce) or out (increase). The position of the damper can be read on the damper scale (C).

Check the air adjustment by making a flue gas analysis.

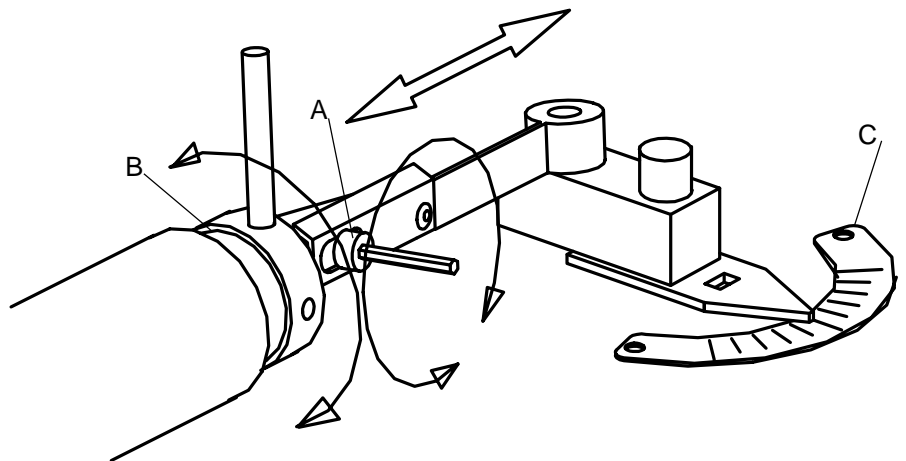

MAINTENANCE OF OIL BURNER

Warning: Before doing any service switch off power at the main switch and cut off the oil supply.

SERVICE OF BURNER HEAD

(alt. A)

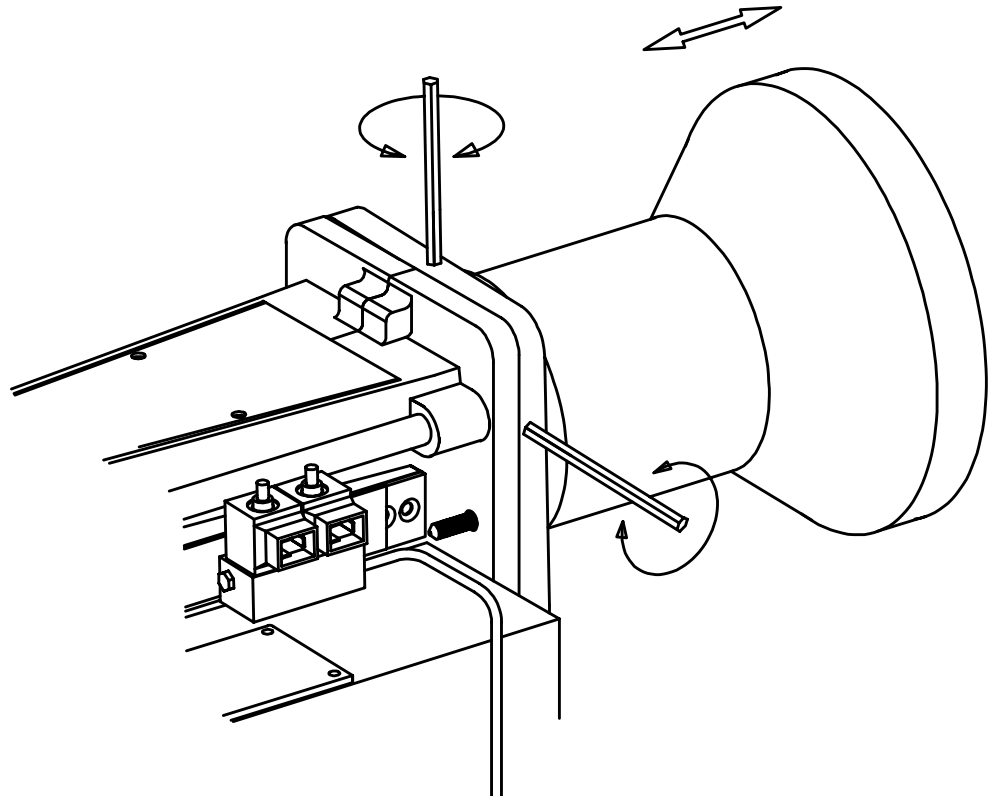

SERVICE OF BURNER HEAD

(alt. B)

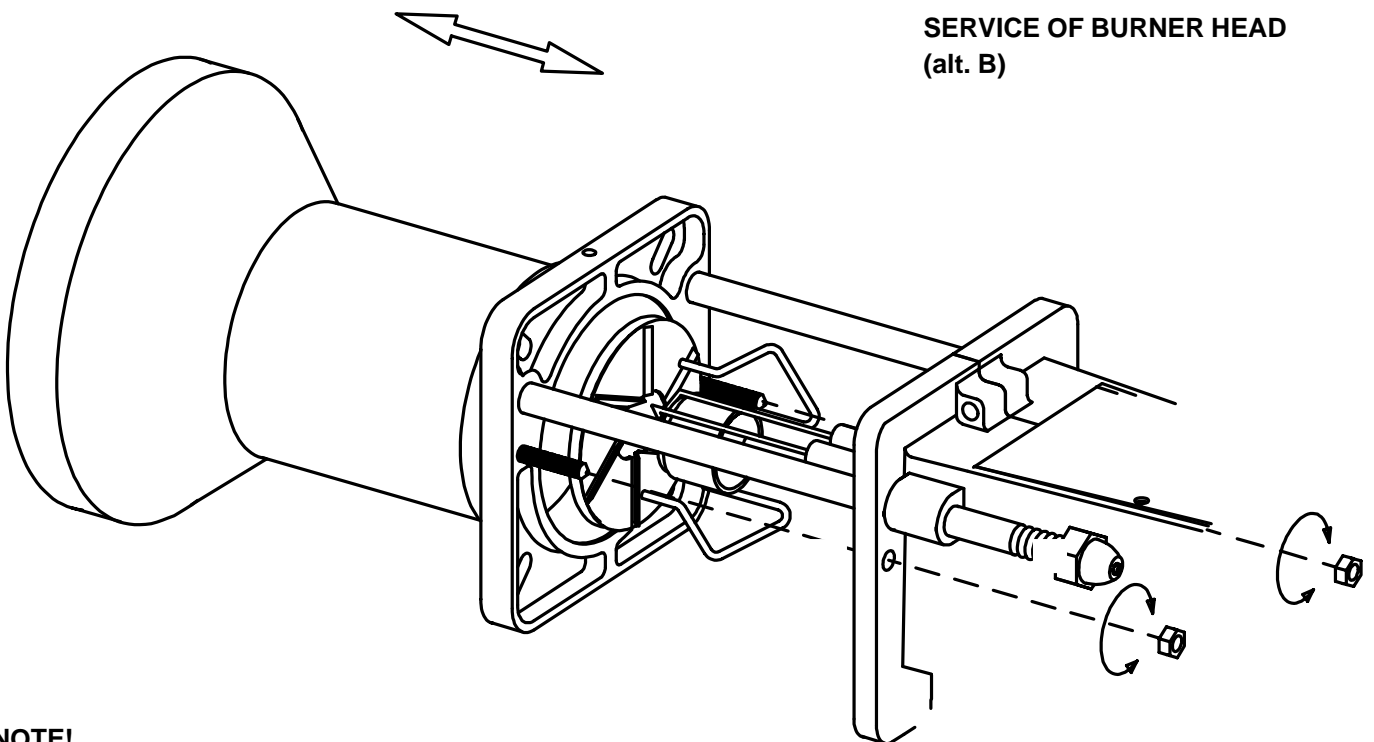

NOTE!

For maintenance of the brake plate, nozzles, electrodes etc, when using a long design of the burner tube, you have to **remove the nozzle assembly from the connecting pipe and move the assembly backwards** in the fan housing (from the boiler).

ELECTRIC EQUIPMENT

OIL BURNER CONTROL: LOA21.173A27/LOA24.173A27/LOA44/BHO61.A/B

WIRING DIAGRAM

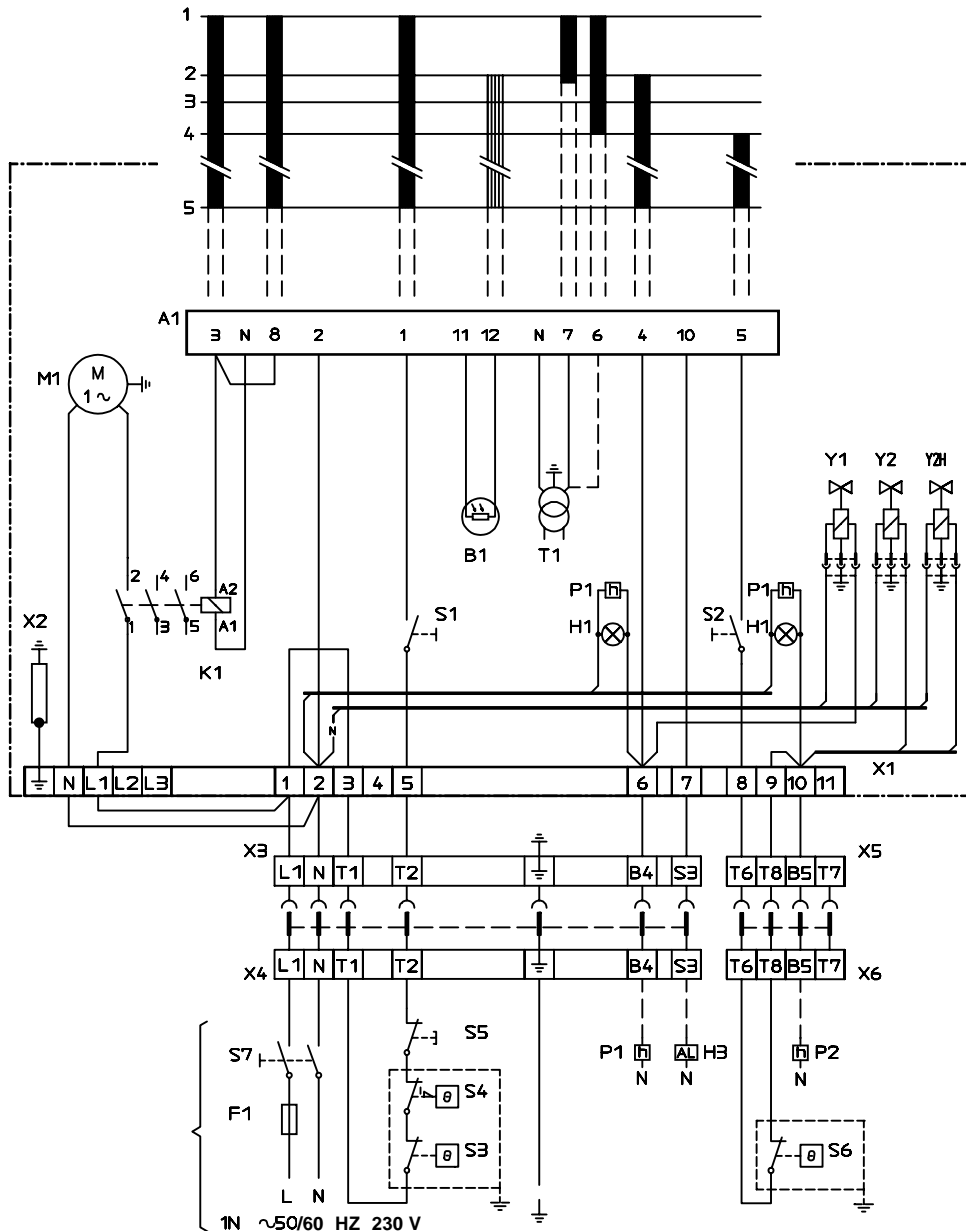

LIST OF COMPONENTS

- A1 Oil burner control
- B1 Photoresistor
- F1 Fuse
- H1 Lamp, low capacity
- H3 Lamp, lock-out signal 220 V
- K1 Thermal overload protection
- M1 Burner motor
- P1 Time meter, low capacity (optional)
- P2 Time meter, high capacity (optional)
- S1 Operating switch
- S2 Operating switch, high/low capacity
- S3 Control thermostat
- S4 Temperature limiter
- S5 Micro switch for hinged door
- S6 Control thermostat, high/low capacity
- S7 Main switch
- T1 Ignition transformer
- X1 Connection terminal board
- X2 Earth terminal
- X3 Plug-in contact "Euro", burner
- X4 Plug-in contact "Euro", boiler
- X5 Plug-in contact "Euro", high/low burner
- X6 Plug-in contact "Euro", high/low boiler
- Y1 Solenoid valve 1
- Y2 Solenoid valve 2
- Y2H Solenoid valve, Hydraulic piston
(Only 2-stage burners with 1 nozzle.)

If S6 is missing connection between T6 and T8.

Mains connection and fuse in accordance with local regulations.

ELECTRIC EQUIPMENT

OIL BURNER CONTROL: LOA21.173A27/LOA24.173A27/BHO61.A/B

FUNCTION

1. Switch on operating switch and twin thermostat
The burner motor starts, an ignition spark is formed, the prepurge goes on till the prepurge period expires and the solenoid valve 1 opens (2).
2. Solenoid valve 1 opens
Oil mist is formed and ignited. The photocell indicates a flame.
3. The safety time expires
 - a. If no flame is established before this time limit the control cuts out.
 - b. If for some reasons the flame disappears after this time limit, the burner will make an attempt to re-start.
4. Full load thermostat ON
The ignition spark goes out 2 s after flame indication when the ignition transformer is connected to terminal 7. The burner is in operating position and can now change between high and low capacity.
- 4-5. Operating position
If the burner operation is interrupted by means of the main switch or the thermostat, a new start takes place when the conditions in accordance with point 1 are fulfilled.

The oil burner control cuts out

A red lamp in the control is lit. Press the reset button and the burner re-starts.

Post-ignition

If a post-ignition of 15 s is wanted, move the ignition transformer from terminal 7 to terminal 6.

TECHNICAL DATA

Pre-ignition time:	13 s
Pre-purge time:	13 s
Post-ignition time:	2 s
Safety lock-out time:	10 s
Reset time after lockout:	min. 50 s
Reaction time on flame failure:	max. 1 s
Ambient temperature:	from - 20 to +60°C
Min. current with flame established:	65 μ A
Max. photo current at start:	5 μ A
Enclosure:	IP 40

(Under voltage proof only LOA24.173A27)

CONTROL OF PHOTO CURRENT

Current through photo unit is measured with a d.c. ammeter (a moving coil instrument connected in series with the photo unit).

INSTRUCTIONS PUMP TYPE SUNTEC A2L 65C - 75C

TECHNICAL DATA

One or two-pipe system.

Viscosity range: 2-12 mm²/S

Pressure range: 8-15 bar

Rated voltage of coil: 220/240V

50/60 Hz

Oil temperature: max 60°C

COMPONENTS

1. Nozzle outlet G 1/8"
Stage 2
2. Pressure gauge port G 1/8"
3. Nozzle outlet G 1/8"
Stage 1
4. Pressure gauge port G 1/8"
5. Vacuum gauge port G 1/8"
6. Return line G 1/4"
and internal by-pass plug
7. Suction line G 1/4"
8. Return plug
9. Pressure adjustment

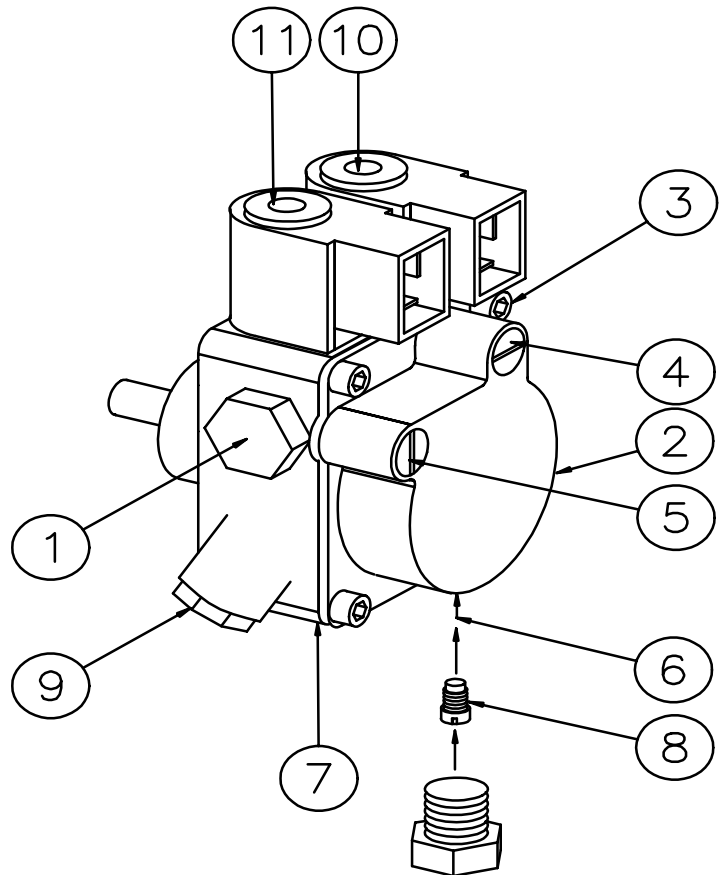

SUCTION LINE TABLES

The suction line tables consist of theoretically calculated values where the pipe dimensions and oil velocity have been matched so that turbulences will not occur. Such turbulences will result in increased pressure losses and in acoustic noise in the pipe system. In addition to drawn copper piping a pipe system usually comprises 4 elbows, a non-return valve, a cut-off valve and an external oil filter.

The sum of these individual resistances is so insignificant that they can be disregarded. The tables do not include any lengths exceeding 100 m as experience shows that longer lengths are not needed.

The tables apply to a standard fuel oil of normal commercial quality according to current standards. On commissioning with an empty tube system the oil pump should not be run without oil for more than 5 min. (a condition is that the pump is being lubricated during operation).

The tables state the total suction line length in metres at a nozzle capacity of 9,5 Gph. Max. permissible pressure at the suction and pressure side is 2,0 bar.

1-pipe system				
Height	Pipe diameter			
H	ø6 mm	ø8 mm	ø10 mm	
m	m	m	m	
4,0	45	144	150	
3,0	39	127	150	
2,0	34	109	150	
1,0	28	92	150	
0,5	26	83	150	
0,0	23	74	150	
With an underlying tank a 1-pipe-system is not recommended				
Two-pipe system				
Height	Pipe diameter			
H	ø8mm	ø10mm	ø12mm	ø14mm
m	m	m	m	m
4,0	42	108	150	150
3,0	36	94	150	150
2,0	31	81	150	150
1,0	26	68	144	150
0,5	23	61	130	150
0,0	20	54	116	150
Two-pipe system				
Height	Pipe diameter			
H	ø8mm	ø10mm	ø12mm	ø14mm
m	m	m	m	m
0,0	20	54	116	150
-0,5	17	48	103	150
-1,0	15	41	89	150
-2,0	9	28	61	116
-3,0	4	14	33	65
-4,0	0	0	6	14

PUMP OPERATING PRINCIPLE FOR A2L 65C - 75C

The **SUNTEC A2L** oil pump has two nozzle outlets. It incorporates two blocking solenoid valves with in-line-cut-off function, one for each nozzle outlet.

The gear set draws oil from the tank through the built-in filter and transfers it to the nozzle line via the cut-off solenoid valves. A pressure regulating valve is used to dump all oil which is not required at the nozzle.

In one-pipe operation, the oil which does not go through the nozzle lines is returned directly to the gear inlet and the suction line flow is equal to the sum of the 2 nozzle flows. In two-pipe operation, the by-pass plug must be fitted in the return port, which ensures that the oil dumped by the regulating valve is returned to the tank and the suction line flow is equal to the gear set capacity.

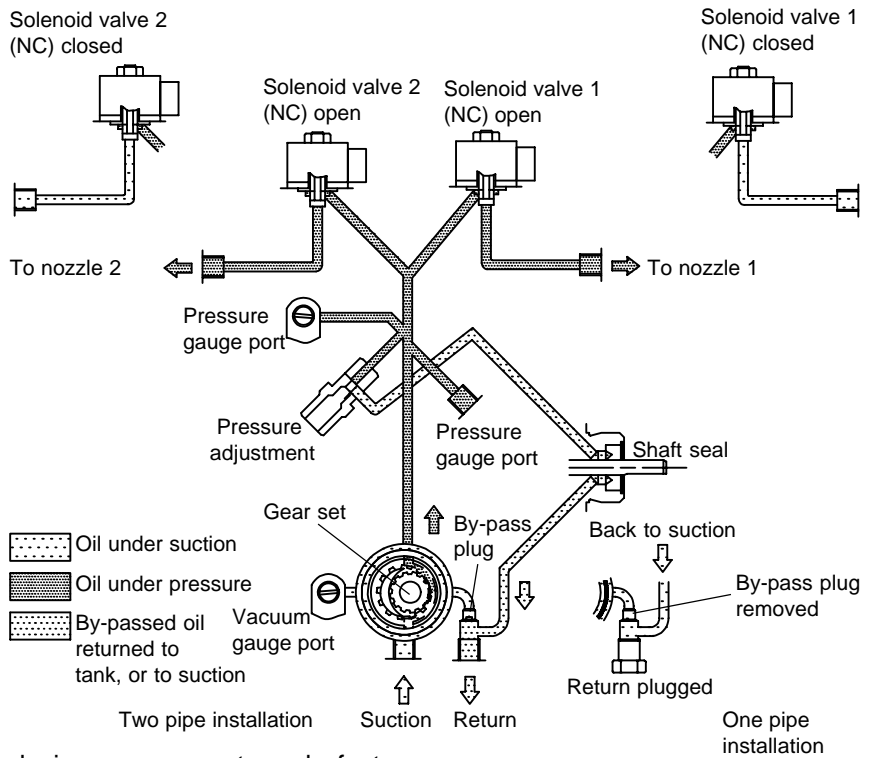

design ensures extremely fast response and the switching can be selected according to the burner operating sequence and is independent of motor speed.

When the solenoids are non-activated, the valves are closed and all oil pressurised by the gear set passes through the regulator to suction or to the return line, depending upon pipe arrangement.

As soon as the solenoids are activated, oil passes to the nozzle lines at the pressure set by the pressure regulating valve.

Shaft rotation and nozzle location seen from shaft end

Gear set capacity

A2L: 2 nozzle outlets

A2LXX C

BLEED

Bleeding in two-pipe operation is automatic: it is assured by a bleed flat on the piston. In one-pipe operation, a high pressure connection must be loosened until the air is evacuated from the system.

CUT-OFF

The solenoid valves of the A2L pump are of the "normally closed" type and are situated in the nozzle lines. This

EXCHANGE OF FILTER

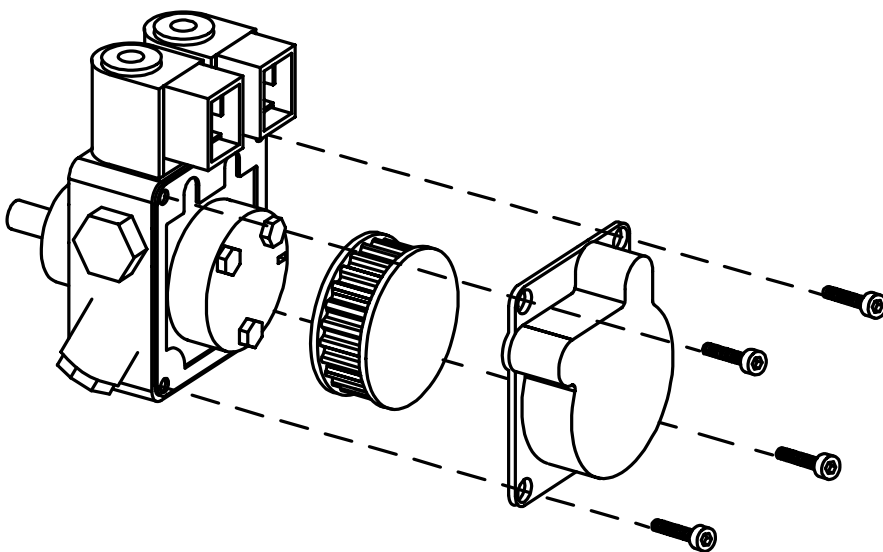

MOUNTING/DISMOUNTING RETURN PLUG

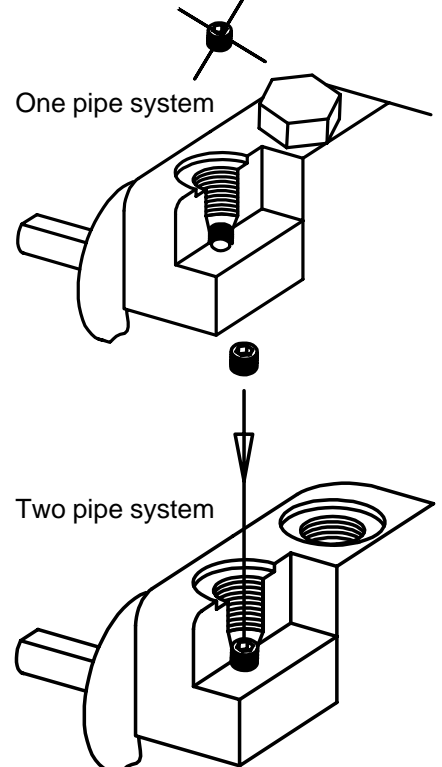

NOZZLE TABLE

Pump pressure bar

Gph	8			9			10			11			12			13			14			15		
	kg/h	kW	Mcal/h	kg/h	kW	Mcal/h	kg/h	kW	Mcal/h	kg/h	kW	Mcal/h	kg/h	kW	Mcal/h	kg/h	kW	Mcal/h	kg/h	kW	Mcal/h	kg/h	kW	Mcal/h
0,40	1,33	16	13	1,41	17	14	1,49	18	15	1,56	18	16	1,63	19	17	1,70	20	17	1,76	21	18	1,82	21	18
0,50	1,66	20	17	1,76	21	18	1,86	22	19	1,95	23	20	2,04	24	21	2,12	25	22	2,20	26	22	2,28	27	23
0,60	2,00	24	20	2,12	25	22	2,23	26	23	2,34	28	24	2,45	29	25	2,55	30	26	2,64	31	27	2,73	32	28
0,65	2,16	26	22	2,29	27	23	2,42	29	25	2,54	30	26	2,65	31	27	2,75	33	28	2,86	34	29	2,96	35	30
0,75	2,49	29	25	2,65	31	27	2,79	33	28	2,93	35	30	3,08	36	31	3,18	38	32	3,30	39	34	3,42	40	35
0,85	2,83	33	29	3,00	36	31	3,16	37	32	3,32	39	34	3,47	41	35	3,61	43	37	3,74	44	38	3,87	46	39
1,00	3,33	39	34	3,53	42	36	3,72	44	38	3,90	46	40	4,08	48	42	4,24	50	43	4,40	52	45	4,56	54	46
1,10	3,66	43	37	3,88	46	39	4,09	48	42	4,29	51	44	4,48	53	46	4,67	55	48	4,84	57	49	5,01	59	51
1,20	3,99	47	41	4,24	50	43	4,47	53	46	4,68	55	48	4,89	58	50	5,09	60	52	5,29	63	54	5,47	65	56
1,25	4,16	49	42	4,40	52	45	4,65	55	47	4,88	58	50	5,10	60	52	5,30	63	54	5,51	65	56	5,70	68	58
1,35	4,49	53	46	4,76	56	48	5,02	59	51	5,27	62	54	5,50	65	56	5,73	68	58	5,95	70	61	6,15	73	63
1,50	4,98	59	51	5,29	63	54	5,58	66	57	5,85	69	60	6,11	72	62	6,36	75	65	6,60	78	67	6,83	81	70
1,65	5,49	65	56	5,82	69	59	6,14	73	63	6,44	76	66	6,73	80	69	7,00	83	71	7,27	86	74	7,52	89	77
1,75	5,82	69	59	6,18	73	63	6,51	77	66	6,83	81	70	7,14	85	73	7,42	88	76	7,71	91	79	7,97	94	81
2,00	6,65	79	68	7,06	84	72	7,45	88	76	7,81	93	80	8,18	97	83	8,49	101	86	8,81	104	90	9,12	108	93
2,25	7,49	89	76	7,94	94	81	8,38	99	85	8,78	104	89	9,18	109	94	9,55	113	97	9,91	117	101	10,26	122	105
2,50	8,32	99	85	8,82	105	90	9,31	110	95	9,76	116	99	10,19	121	104	10,61	126	108	11,01	130	112	11,39	135	116
2,75	9,15	108	93	9,71	115	99	10,24	121	104	10,73	127	109	11,21	133	114	11,67	138	119	12,11	144	123	12,53	148	128
3,00	9,98	118	102	10,59	126	108	11,16	132	114	11,71	139	119	12,23	145	125	12,73	151	130	13,21	157	135	13,67	162	139
3,50	11,65	138	119	12,35	146	126	13,03	154	133	13,66	162	139	14,27	169	145	14,85	176	151	15,42	183	157	15,95	189	163
4,00	13,31	158	136	14,12	167	144	14,89	176	152	15,62	185	159	16,31	193	166	16,97	201	173	17,62	209	180	18,23	216	186
4,50	14,97	177	153	15,88	188	162	16,75	198	171	17,57	208	179	18,35	217	187	19,10	226	195	19,82	235	202	20,51	243	209
5,00	16,64	197	170	17,65	209	180	18,62	221	190	19,52	231	199	20,39	242	208	21,22	251	216	22,03	261	225	22,79	270	232
5,50	18,30	217	187	19,42	230	198	20,48	243	209	21,47	255	219	22,43	266	229	23,34	277	238	24,23	287	247	25,07	297	256
6,00	19,97	237	204	21,18	251	216	22,34	265	228	23,42	278	239	24,47	290	249	25,46	302	260	26,43	313	269	27,49	326	280
6,50	21,63	256	220	22,94	272	234	24,20	287	247	25,37	301	259	26,51	314	270	27,58	327	281	28,63	339	292	29,63	351	302
7,00	23,29	276	237	24,71	293	252	26,06	309	266	27,33	324	279	28,55	338	291	29,70	352	303	30,84	366	314	31,91	378	325
7,50	24,96	296	254	26,47	314	270	27,92	331	285	29,28	347	298	30,59	363	312	31,83	377	324	33,04	392	337	34,19	405	349
8,00	26,62	316	271	28,24	335	288	29,79	353	304	31,23	370	318	32,63	387	333	33,95	403	346	35,25	418	359	36,47	432	372
8,50	28,28	335	288	30,00	356	306	31,65	375	323	33,18	393	338	34,66	411	353	36,07	428	368	37,45	444	382	38,74	459	395
9,00	29,95	355	305	31,77	377	324	33,59	398	342	35,14	417	358	36,71	435	374	38,19	453	389	39,65	470	404	41,02	486	418

 The table applies to oil with a viscosity of 4,4 mm²/s (cSt) with density 830 kg/m³.

BURNER WITH PREHEATER

Consider that on preheating the oil quantity is reduced by 5-20% depending on.

- Rise in temperature at the nozzle
- Design of nozzle
- Capacity (high capacity - small difference)

NOZZLE TABLE

Pump pressure bar

Gph	10			11			12			13			14			15			16			17		
	kg/h	kW	Mcal/h	kg/h	kW	Mcal/h	kg/h	kW	Mcal/h	kg/h	kW	Mcal/h	kg/h	kW	Mcal/h	kg/h	kW	Mcal/h	kg/h	kW	Mcal/h	kg/h	kW	Mcal/h
1,00	3,72	44	38	3,90	46	40	4,08	48	42	4,24	50	43	4,40	52	45	4,56	54	46	4,71	56	48	4,85	57	49
1,10	4,09	48	42	4,29	51	44	4,48	53	46	4,67	55	48	4,84	57	49	5,01	59	51	5,18	61	53	5,34	63	54
1,20	4,47	53	46	4,68	55	48	4,89	58	50	5,09	60	52	5,29	63	54	5,47	65	56	5,65	67	58	5,82	69	59
1,25	4,65	55	47	4,88	58	50	5,10	60	52	5,30	63	54	5,51	65	56	5,70	68	58	5,89	70	60	6,07	72	62
1,35	5,02	59	51	5,27	62	54	5,50	65	56	5,73	68	58	5,95	70	61	6,15	73	63	6,36	75	65	6,55	78	67
1,50	5,58	66	57	5,85	69	60	6,11	72	62	6,36	75	65	6,60	78	67	6,83	81	70	7,06	84	72	7,27	86	74
1,65	6,14	73	63	6,44	76	66	6,73	80	69	7,00	83	71	7,27	86	74	7,52	89	77	7,77	92	79	8,01	95	82
1,75	6,51	77	66	6,83	81	70	7,14	85	73	7,42	88	76	7,71	91	79	7,97	95	81	8,24	98	84	8,49	101	87
2,00	7,45	88	76	7,81	93	80	8,16	97	83	8,49	101	87	8,81	104	90	9,12	108	93	9,42	112	96	9,71	115	99
2,25	8,38	99	85	8,78	104	90	9,18	109	94	9,55	113	97	9,91	118	101	10,26	122	105	10,60	126	108	10,92	130	111
2,50	9,31	110	95	9,76	116	100	10,19	121	104	10,61	126	108	11,01	131	112	11,39	135	116	11,77	140	120	12,13	144	124
2,75	10,24	121	104	10,73	127	109	11,21	133	114	11,67	138	119	12,11	144	123	12,53	149	128	12,95	154	132	13,35	158	136
3,00	11,16	132	114	11,71	139	119	12,23	145	125	12,73	151	130	13,21	157	135	13,67	162	139	14,13	168	144	14,56	173	148
3,50	13,03	154	133	13,66	162	139	14,27	169	146	14,85	176	151	15,42	183	157	15,95	189	163	16,49	196	168	16,99	201	173
4,00	14,89	176	152	15,62	185	159	16,31	193	166	16,97	201	173	17,62	209	180	18,23	216	186	18,84	223	192	19,42	230	198
4,50	16,75	199	171	17,57	208	179	18,35	218	187	19,10	226	195	19,82	235	202	20,51	243	209	21,20	251	216	21,84	259	223
5,00	18,62	220	190	19,52	231	199	20,39	242	208	21,22	252	216	22,03	261	225	22,79	270	232	23,55	279	240	24,27	288	247
5,50	20,48	243	209	21,47	255	219	22,43	266	229	23,34	277	238	24,23	287	247	25,07	297	256	25,91	307	264	26,70	317	272
6,00	22,34	265	228	23,42	278	239	24,47	290	250	25,46	302	260	26,43	313	270	27,49	326	280	28,27	335	288	29,13	345	297
6,50	24,20	287	247	25,37	301	259	26,51	314	270	27,58	327	281	28,63	340	292	29,63	351	302	30,62	363	312	31,55	374	322
7,00	26,06	309	266	27,33	324	279	28,55	339	291	29,70	352	303	30,84	366	314	31,91	378	325	32,98	391	336	33,98	403	347
7,50	27,92	331	285	29,28	347	299	30,59	363	312	31,83	377	325	3,04	392	337	34,19	405	349	35,33	419	360	36,41	432	371
8,00	29,79	353	304	31,23	370	318	32,63	387	333	33,95	403	346	35,25	418	359	36,47	433	372	37,69	447	384	38,80	460	396
8,50	31,65	375	323	33,18	393	338	34,66	411	353	36,07	428	368	37,45	444	382	38,74	459	395	40,04	475	408	41,26	489	421
9,00	33,59	398	343	35,14	417	358	37,71	435	374	38,19	453	389	39,65	470	404	41,02	486	418	42,40	503	432	43,69	518	446
9,50	35,37	419	361	37,09	440	378	38,74	459	395	40,31	478	411	41,85	496	427	43,30	514	442	44,75	531	456	46,11	547	470
10,00	37,23	441	380	39,04	463	398	40,78	484	416	42,44	503	433	44,06	523	449	45,58	541	465	47,11	559	480	47,11	559	480
11,00	40,96	486	418	42,94	509	438	44,86	532	457	46,68	554	476	48,46	575	494	50,14	595	511	51,82	615	528	53,40	633	545
12,00	44,68	530	456	46,85	556	478	48,94	580	499	50,92	604	519	52,87	627	539	54,70	648	558	56,53	670	576	58,25	691	594
14,00	52,12	618	531	54,65	648	557	57,10	677	582	59,41	705	606	62,68	732	629	63,81	757	651	65,95	778	669	67,96	806	693
16,00	59,57	706	607	62,46	741	637	65,26	774	666	67,90	805	692	70,49	836	719	72,93	865	744	75,38	894	769	77,67	921	792
18,00	67,02	795	683	70,27	833	717	73,41	871	749	76,39	906	779	79,30	940	809	82,05	973	837	84,80	1006	865	87,38	1036	891
20,00	74,47	883	759	78,08	926	796	81,57	967	832	84,87	1007	865	88,11	1045	899	91,17	1081	930	94,22	1117	961	97,09	1151	990
22,00	81,91	971	835	85,89	1019	876	89,73	1064	915	93,36	1107	952	96,92	1149	988	100,28	1189	1023	103,64	1229	1057	106,79	1267	1089
24,00	89,36	1060	911	93,70	1111	956	97,88	1161	998	101,85	1208	1039	105,74	1254	1078	109,40	1297	1116	113,06	1341	1153	116,50	1382	1188
26,00	96,81	1148	987	101,50	1204	1035	106,04	1258	1081	110,33	1308	1125	114,55	1359	1168	118,52	1406	1209	122,49	1453	1249	126,21	1497	1287

The table applies to oil with a viscosity of 4,4 mm²/s (cSt) with density 830 kg/m³.

NOZZLE TABLE

Pump pressure bar

Gph	18			19			20			21			22			23			24			25		
	kg/h	kW	Mcal/h	kg/h	kW	Mcal/h	kg/h	kW	Mcal/h	kg/h	kW	Mcal/h	kg/h	kW	Mcal/h	kg/h	kW	Mcal/h	kg/h	kW	Mcal/h	kg/h	kW	Mcal/h
1,00	4,99	59	51	5,13	61	52	5,26	62	54	5,40	64	55	5,53	66	56	5,65	67	58	5,77	68	59	5,89	70	60
1,10	5,49	65	56	5,64	67	57	5,79	69	59	5,93	70	60	6,07	72	62	6,21	74	63	6,34	75	65	6,47	77	66
1,20	5,99	71	61	6,16	73	63	6,32	75	64	6,47	77	66	6,62	78	67	6,77	80	69	6,92	82	71	7,06	84	72
1,25	6,24	74	64	6,41	76	65	6,58	78	67	6,74	80	69	6,90	82	70	7,05	84	72	7,21	85	73	7,35	87	75
1,35	6,74	80	69	6,93	82	71	7,11	84	72	7,28	86	74	7,45	88	76	7,62	90	78	7,78	92	79	7,94	94	81
1,50	7,48	89	76	7,69	91	78	7,89	93	80	8,08	96	82	8,27	98	84	8,46	100	86	8,64	102	88	8,82	105	90
1,65	8,24	98	84	8,47	100	86	8,69	103	89	8,90	105	91	9,11	108	93	9,31	110	95	9,51	113	97	9,71	115	99
1,75	8,78	104	90	8,98	106	92	9,21	109	94	9,44	112	96	9,66	115	98	9,88	117	101	10,09	120	103	10,30	122	105
2,00	9,99	118	102	10,26	122	105	10,53	125	107	10,79	128	110	11,04	131	113	11,29	134	115	11,53	137	118	11,77	140	120
2,25	11,24	133	115	11,55	137	118	11,85	140	121	12,14	144	124	12,43	147	127	12,70	151	129	12,98	154	132	13,25	157	135
2,50	12,48	148	127	12,83	152	131	13,16	156	134	13,49	160	138	13,81	164	141	14,12	167	144	14,42	171	147	14,72	175	150
2,75	13,73	163	140	14,11	167	144	14,48	171	148	14,84	176	151	15,19	180	155	15,53	184	158	15,86	188	162	16,19	192	165
3,00	14,98	178	153	15,39	182	157	15,79	187	161	16,18	192	165	16,18	192	165	16,93	201	173	17,30	205	176	17,65	209	180
3,50	17,48	207	178	17,96	213	183	18,43	218	188	18,89	224	193	19,33	229	197	19,77	234	202	20,19	239	206	20,61	244	210
4,00	19,98	237	204	20,53	243	209	21,06	250	215	21,59	256	220	22,10	262	225	22,59	268	230	23,08	274	235	23,56	279	240
4,50	22,47	266	229	23,09	274	235	23,69	281	242	24,28	288	248	24,85	295	253	25,41	301	259	25,96	308	265	26,49	314	270
5,00	24,97	296	255	25,65	304	262	26,33	312	268	26,98	320	275	27,61	327	282	28,24	335	288	28,84	342	294	29,44	349	300
5,50	27,47	326	280	28,22	335	288	28,96	343	295	29,68	352	303	30,38	360	310	31,06	368	317	31,73	376	324	32,38	384	330
6,00	29,97	355	306	30,79	365	314	31,59	374	322	32,38	384	330	33,14	393	338	33,89	402	346	34,62	411	353	35,33	419	360
6,50	32,46	385	331	33,35	395	340	34,22	406	349	35,07	416	358	35,90	426	366	36,70	435	374	37,49	445	382	38,26	454	390
7,00	34,96	415	356	35,92	426	366	36,86	437	376	37,77	448	385	38,56	457	393	39,53	469	403	40,38	479	412	41,21	489	420
7,50	37,46	444	382	38,49	456	399	39,49	468	403	40,47	480	413	41,42	491	422	42,35	504	434	43,26	513	441	44,16	524	450
8,00	39,96	474	407	41,05	487	419	42,12	499	429	43,17	512	440	44,19	524	451	45,18	536	461	46,15	547	471	47,10	559	480
8,50	42,45	503	433	43,62	517	445	44,75	531	456	45,87	544	468	46,95	557	479	48,00	569	489	49,03	581	500	50,05	594	510
9,00	44,95	533	458	46,18	548	471	47,39	562	483	48,57	576	495	49,71	589	507	50,83	603	518	51,92	616	529	52,99	628	540
9,50	47,45	563	484	48,75	578	497	50,02	593	510	51,26	608	523	52,47	622	535	53,65	636	547	54,80	650	559	55,93	663	570
10,00	49,94	592	509	51,32	609	523	52,66	624	537	53,96	640	550	55,23	655	563	56,47	670	576	57,69	684	588	58,88	698	600
11,00	54,94	652	560	56,45	669	576	57,92	687	591	59,36	704	605	60,76	721	620	62,12	737	633	63,46	753	647	64,77	768	660
12,00	59,93	711	611	61,58	730	628	63,19	749	644	64,76	768	660	66,28	786	676	67,77	804	691	69,23	821	706	70,66	838	721
14,00	69,92	829	713	71,84	852	733	73,72	874	752	75,55	896	770	77,33	917	789	79,07	938	806	80,77	958	824	82,43	978	841
16,00	79,91	948	815	82,11	974	837	84,25	999	859	86,34	1024	880	88,37	1048	901	90,36	1072	921	92,30	1095	941	94,20	1117	961

The table applies to oil with a viscosity of 4,4 mm²/s (cSt) with density 830 kg/m³.

FAULT LOCATION

BURNER FAILS TO START

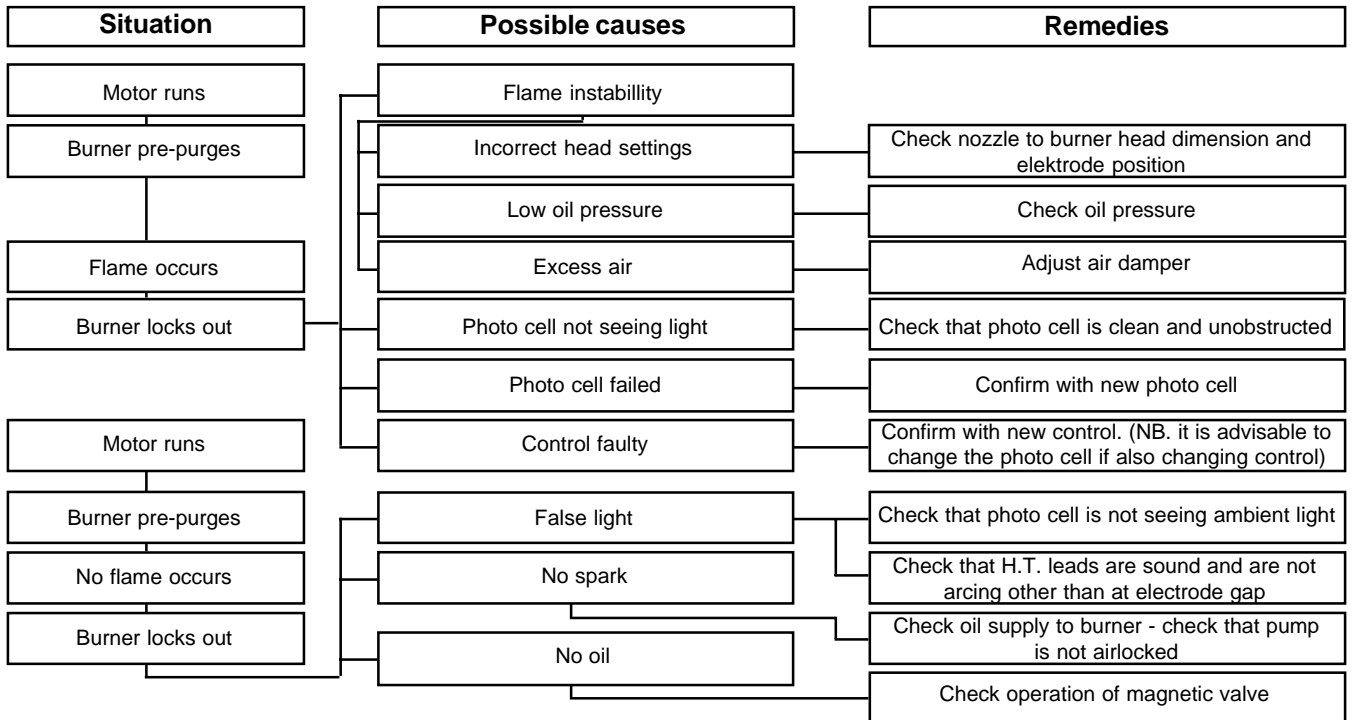

BURNER FAILS TO START AFTER NORMAL OPERATION

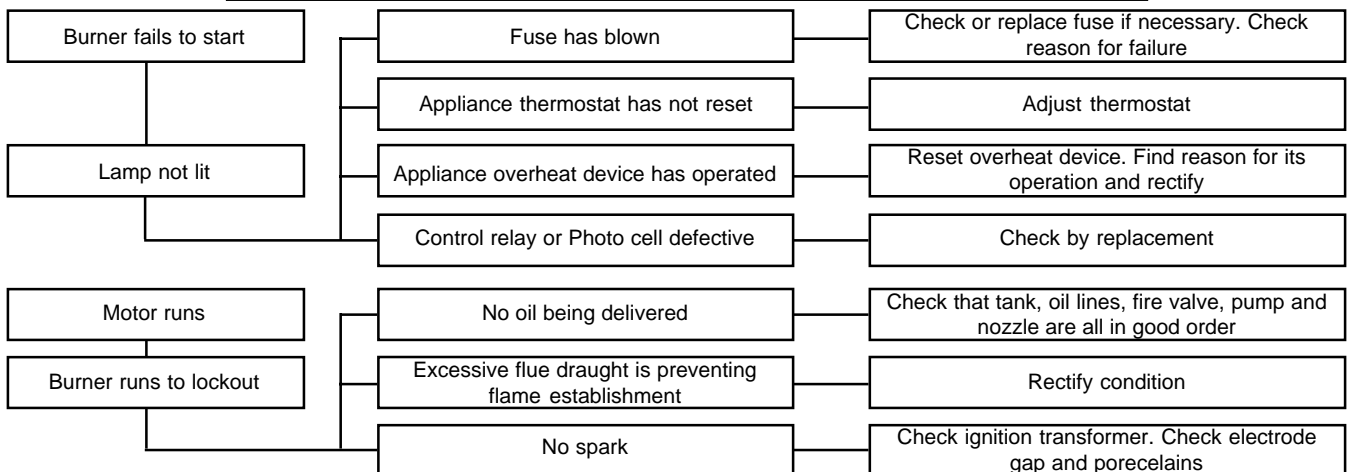

DELAYED IGNITION, BURNERS STARTS VIOLENTLY

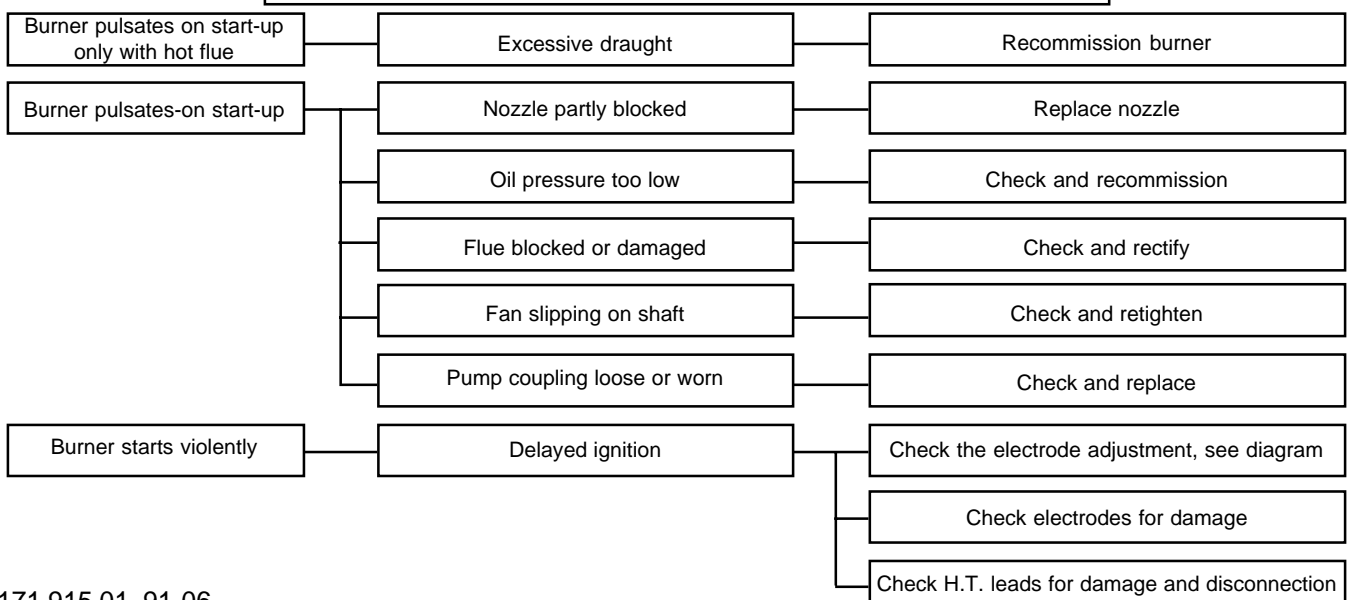

DECLARATION OF CONFORMITY

We
(supplier's name)

BENTONE AB

(address)

P.O. Box 309, S-341 26 Ljungby, Sverige

declare under our sole responsibility that the product
(name, type or model, batch or serial number, possibly sources and number of items)

ST 97, ST 108, ST 120, ST 133, ST 146, B 9, B 10, B 11, B 20, B 30, B 40, B 45, B 50, B 60, B 70, B 80, SF 141

and TF 205, fan burners for gasoil

to which this declaration relates is in conformity with the following standard(s) or the normative document(s)
(title and/or number and date of issue of the standard(s) or other normative document(s))

DIN 4787 and EN 267

following the provisions of Directive
(if applicable)

EMC directive 89 / 336 / EEC, Low voltage directive 73 / 23 / EEC and Machinery directive 89/392/EEC.

Re. the Efficiency directive 92/42/EEC, please see the next page.

Ljungby, 25th May, 1999

(Place and date of issue)

BENTONE AB

Ulf Bondeson

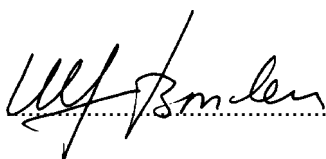

(name and signature of equivalent marking of authorized person)

To fulfil the demands according to the Efficiency directive 92/42/EEC, Article 2, we herewith state the following parameters.

Burner type	Capacity kg/h (kW)	Test report No. TÜV	Pressure in combustion chamber mbar	Product ID-No. as per EC-Type Examination Certificate
ST 97	1,2-2,6 (14,2-30,8)	3728 (15.03.96)	-0,2 to+1,4 to + 0,1	CE 0036 0128/98
ST 108	1,2-3,8 (14,2-45)	3729 (15.03.96)	-0,2 to + 1,4 to + 0,2	CE 0036 0129/98
ST 120	2,1-4,5 (24,9-53,3)	3581 (10.11.94)	-0,2 to + 1,9 to + 0,2	CE 0036 0130/98
ST 133	2,0-10,0 (23,7-118,5)	3795 (12.11.96)	-0,2 to + 2,2 to + 0,1	CE 0036 0131/98
ST 146	4,0-10,0 (47,4-118,5)	3796 (12.11.96)	-0,2 to + 3,9 to + 0,1	CE 0036 0132/98
B 9	1,2-2,5 (14,2-29,6)	3341 (21.08.92)	-0,2 to + 0,8 to + 0,1	CE 0036 0133/98
B 10	1,4-3,0 (16,6-35,6)	3465 (03.09.93)	-0,2 to + 1,1 to + 0,25	CE 0036 0134/98
B 10KA	2,0-4,6 (23,7-54,5)	3778 (18.10.96)	-0,2 to + 0,95 to + 0,1	CE 0036 0135/98
B 10ZHV	1,2-2,5 (14,2-29,5)	3525 (21.01.94)	-0,2 to + 1,0 to + 0,3	CE 0036 0136/98
B 11				
B 20K	4,3-9,8 (51,0-116,1)	3779 (18.10.96)	-0,2 to + 1,15 to + 0,1	CE 0036 0137/98
B 20KA	2,0-8,0 (23,7-94,8)	3333 (04.08.92)	-0,2 to 0,78 to + 0,1	CE 0036 0138/98
B 20ZHV	2,1-4,3 (24,9-51,0)	3397 (14-06.93)	-0,2 to 1,25 to + 0,1	CE 0036 0139/98
B 30	6,0-17,5 (71,1-207,4)	3524 (24.01.94)	-0,2 to + 2,8 to + 0,2	CE 0036 0140/98
B 30A	6,0-17,0 (71,1-207,4)	3797 (12.11.96)	-0,2 to + 3,0 to + 0,1	CE 0036 0141/98
B 30A2	4,5-15,0 (53,3-177,8)	3798 (12.11.96)	-0,2 to 3,8 to + 0,1	CE 0036 0142/98
B 30ZHV-2	3,3-10,0 (39,1-118,5)	3563 (10.11.94)	-0,2 to + 1,3 to + 0,1	CE 0036 0143/98
B 40	9,0-29,5 (106,7-349,6)	3503 (21.09.93)	-0,3 to + 4,1 to + 0,2	CE 0036 0144/98
B 40A	9,0-29,5 (106,7-349,6)	3799 (12.11.96)	-0,2 to + 5,3 to + 0,1	CE 0036 0145/98

To fulfil the demands according to the Efficiency directive 92/42/EEC, Article 2, we herewith state the following parameters.

Burner type	Capacity kg/h (kW)	Test report No. TÜV	Pressure in combustion chamber mbar	Product ID-No. as per EC-Type Examination Certificate
B 50-2F	12,0-59,0 (142,2-699,2)	3390 (09.06.93)	-0,2 to +9,4 to + 0,2	CE 0036 0147/98
B 50-3F	12,0-59,0 (142,2-699,2)	3592 (10.11.94)	-0,2 to + 9,25 to + 0,1	CE 0036 0148/98
B 60-2F	20,0-90,0 (237,0-1066,5)	3466 (03.09.93)	-0,3 to + 11,4 to + 0,8	CE 0036 0149/98
B 60-3F	20,0-90,0 (237,0-1066,5)	3591 (10.11.94)	-0,3 to + 11,4 to + 0,8	CE 0036 0150/98
B 70				
B 80				
SF 141-3	50,0-140,0 (592,5-1659,0)	3502 (16.09.93)	-0,7 to 8,7 to + 12,0 to + 0,1	CE 0036 0151/98
TF 205-3	70,0-205,0	3501 (16.09.93)	-0,7 to + 14,0 to + 16,0 to + 0,1	CE 0036 0152/98
B45A	8,5-47,0 (100,8-557,5)	3977 (16.04.99)	-0,1 to + 0,4 to + 7,0	CE 0036 0250/99
B45A2	8,5-45,5 (100,8-539,7)	3978 (16.04.99)	-0,1 to + 0,4 to + 7,5	CE 0036 0251/99