

B 80-2/3

DESCRIPTION

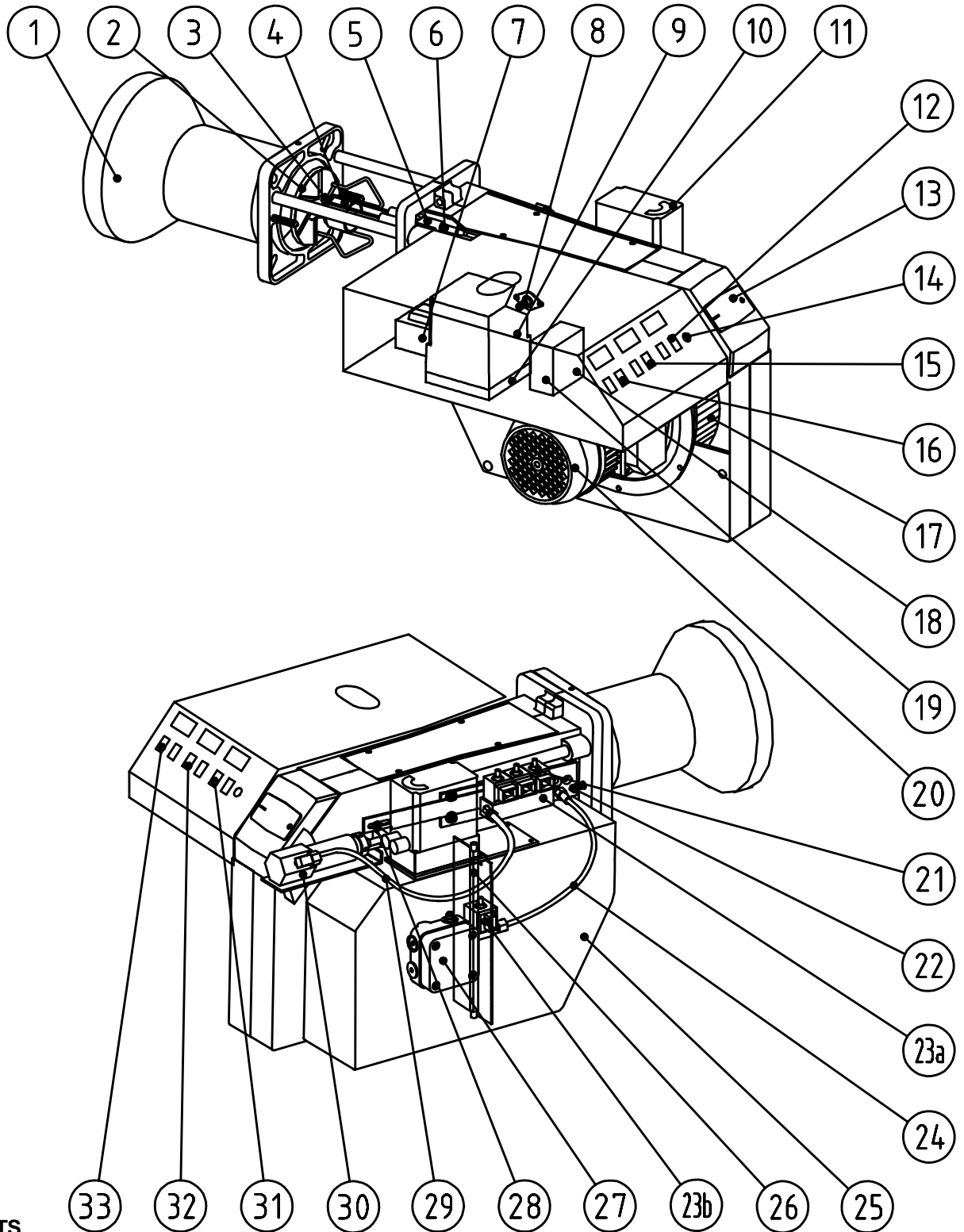

COMPONENTS

- | | | |
|-----------------------------|-------------------------------------------|---------------------------------------------------|
| 1. Flame cone | 14. Fuse | 25. Air intake |
| 2. Shrouded disc | 15. Indicating lamp Stage 2 | 26. Air damper |
| 3. Nozzle | 16. Indicating lamp Stage 1 | 27. Pump |
| 4. Nozzle assembly | 17. Fan wheel | 28. Nozzle assembly adjustment |
| 5. Ignition electrodes | 18. Contactor | 29. Connecting pipe, adjustment device |
| 6. Ignition cable | 19. Thermal overload protection | 30. Adjustment device, Nozzle assembly adjustment |
| 7. Ignition transformer | 20. Motor | 31. Switch II-III |
| 8. Photocell | 21. Solenoid valve | 32. Switch I-II |
| 9. Control box | 22. Locking device, flange | 33. Switch 0-I |
| 10. Relay base | 23a. Solenoid valve bloc | |
| 11. Damper motor | 23b. Safety solenoid valve | |
| 12. Indicating lamp Stage 3 | 24. Connecting pipe, pump-nozzle assembly | |
| 13. Cover, inspection glass | | |

TECHNICAL DATA

Type designation B 80-3F

DIMENSIONS

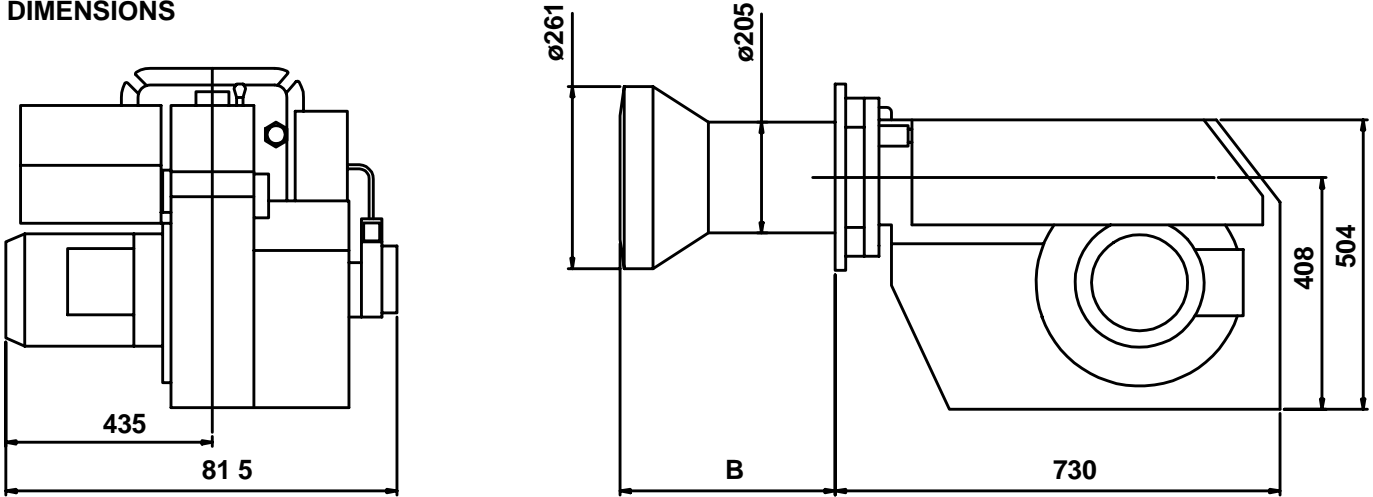

	Length of burner tube	Flange Measure B
Burner head	400	360
Burner head	600	560
Burner head	700	660

OUTPUT RANGE AND NOZZLES RECOMMENDED

	Oil capacity kg/h	Output kW	Output Mcal/h	Recommended nozzle Angle	Danfoss	Monarch	Recommended Pump pressure
Burner head	50-214	593-2538	510-2182	45° - 60°	B	PLP	14 bar

The net calorific value of 11,86 kWh/kg for light oil has been used.

RECOMMENDED NOZZLE

Because of different boiler types existing on the market, with varying combustion chamber designs, it is not possible to

state a definite spray angle or spray pattern.

Note that the spray angle and the spray pattern change with the pump pressure.

BURNER HEAD

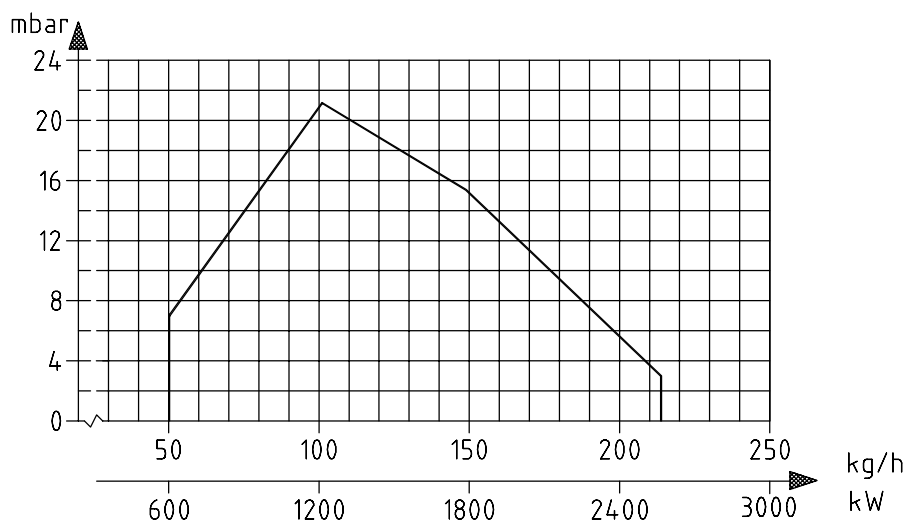
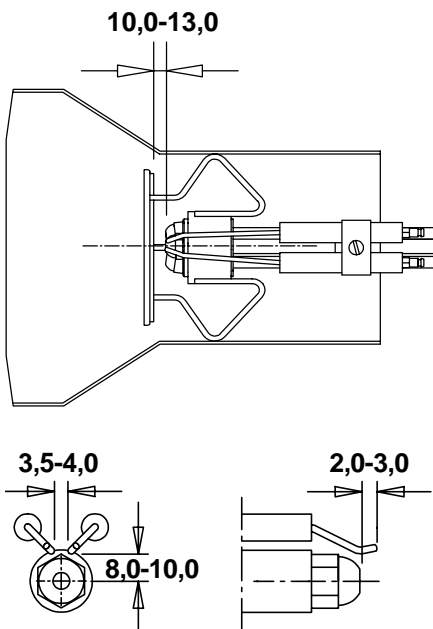

TECHNICAL DATA

DIMENSIONS OF FLANGE

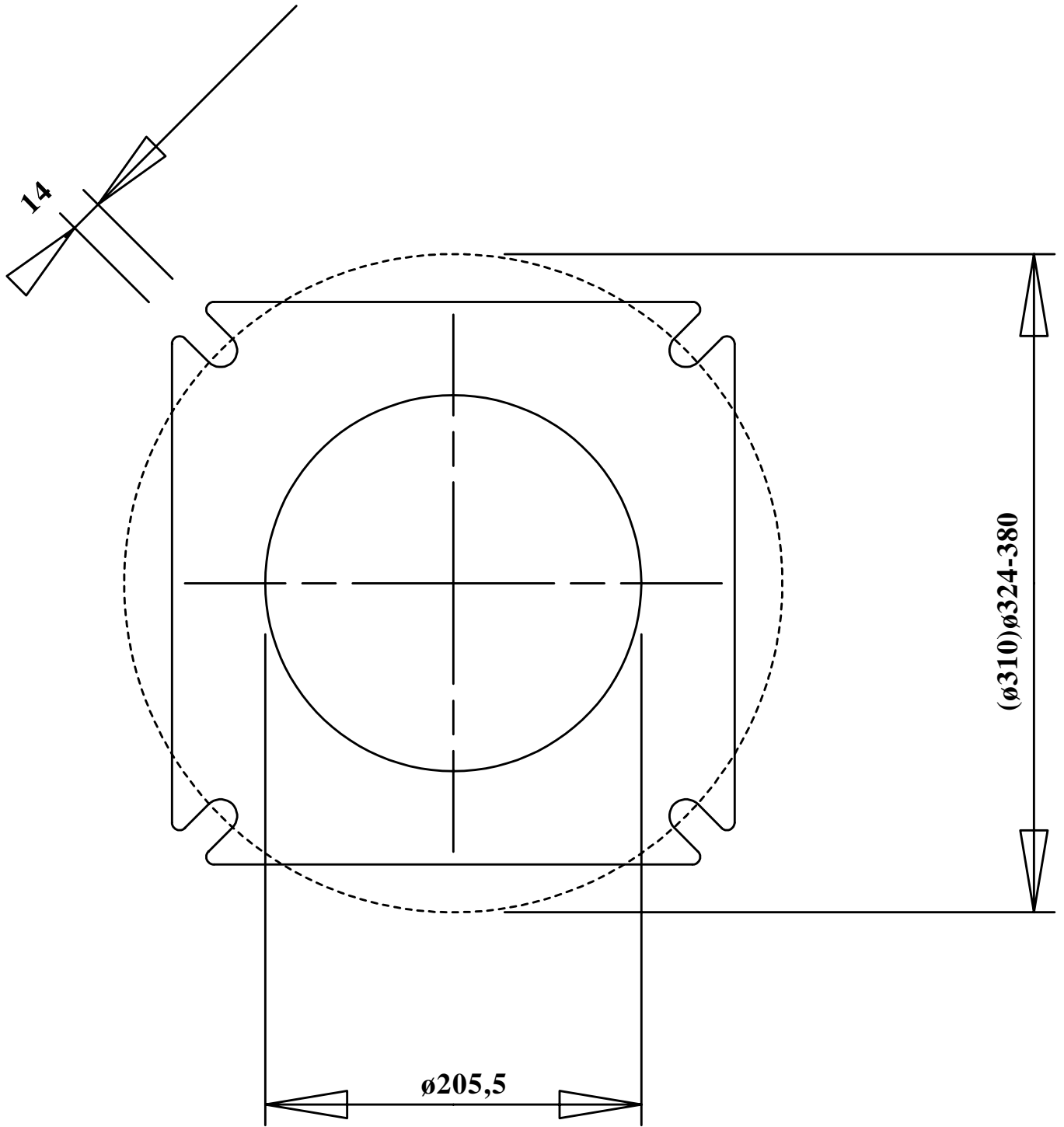

GENERAL INSTRUCTIONS

GENERAL RULES

The installation of an oil burner should be carried out in accordance with local regulations. The installer of the burner must therefore be aware of all regulations relating to oil and combustion.

Only oil suitable for the burner should be used and then in combination with a suitable oil filter before the oil pump of the burner.

If the burner is replacing an existing burner make sure that the oil filter is replaced or cleaned. The installation must only be undertaken by experienced personnel.

INSTALLATION INSTRUCTIONS

General installation instructions accompany the burner and should be left in a prominent place adjacent to the burner.

ADJUSTMENT OF BURNER

The burner is from the factory pre-set to an average value that must then be adjusted to the boiler in question.

All burner adjustments must be made in accordance with boiler manufacturers instructions. These must include the checking of flue gas temperatures, average water temperature and CO₂ or O₂ concentration.

To adjust the combustion device, start by increasing the air volume and the nozzle assembly somewhat. When the burner starts it is burning with excess air and smoke number 0. Reduce the nozzle assembly adjustment until soot occurs, and then increase the adjustment to make the soot disappear again. Then the volume of air is reduced until soot occurs and increased again to reach a combustion free of soot.

By this procedure an optimum adjustment is obtained. If larger nozzles are used the preadjustment of both the air volume and the nozzle assembly must be increased.

A whistling sound may be heard which can be eliminated or reduced as follows: Increase the nozzle assembly adjustment somewhat. The CO₂-content and consequently the air volume will then be reduced.

CONDENSATION IN CHIMNEY

A modern burner works with less excess air and often also with smaller nozzles than older models. This increases the efficiency but also the risk of condensation in the chimney.

The risk increases if the area of the chimney flue is too large. The temperature of the flue gases should exceed 60°C measured 0,5 metres from the chimney top.

Measures to raise the temperature:

Insulate the chimney in cold attics

Install a tube in the chimney

Install a draught regulator (dilutes the flue gases during operation and dries them up during standstill)

Increase the oil quantity

Raise the flue gas temperature by removing turbulators, if any, in the boiler.

PUMP ADJUSTMENT

See separate description.

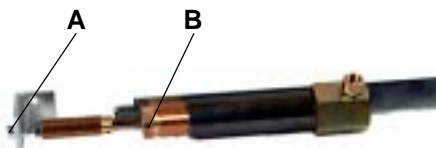

ADJUSTMENT OF NOZZLE ASSEMBLY

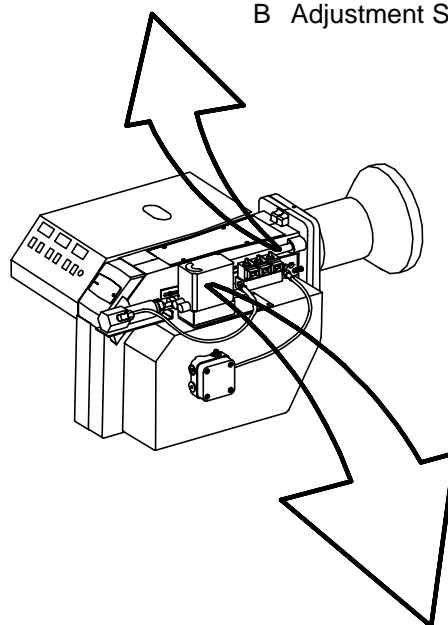

MAINTENANCE

The boiler/burner should be examined regularly for any signs of malfunction or oil leakage

OIL SUPPLY

The oil line should be dimensioned in accordance with the pump manufacturer's instruction. In the suction line to the burner a filter should be mounted to prevent any particles in the oil from reaching the burner. If the installation consists of several burners each one should have its own suction line from the tank or a circulation system should be used.

The temperature in the oil line should be kept as constant as possible. Avoid exposing the line to excessive cold which may cause blockages of paraffin deposits.

The oil pipe and electric cable should be fitted so that the burner can be placed on the floor for inspection of the combustion device.

ADJUSTMENT OF NOZZLE ASSEMBLY

- A Adjustment Stage 1 and Stage 2.
- B Adjustment Stage 3.



AIR ADJUSTMENT

See page "Air adjustment with damper motor".

AIR ADJUSTMENT

The damper motor turns the damper between 3 preset positions: These positions are controlled in the motor by cams which are set by means of the coloured disks. In addition there is a black disk controlling the connection of solenoid valve 2 and a green disk controlling the connection of solenoid valve 3.

If the air volume needs changing: Remove the cover from the damper motor and change the position of the cams by turning them with the tools accompanying the burner.

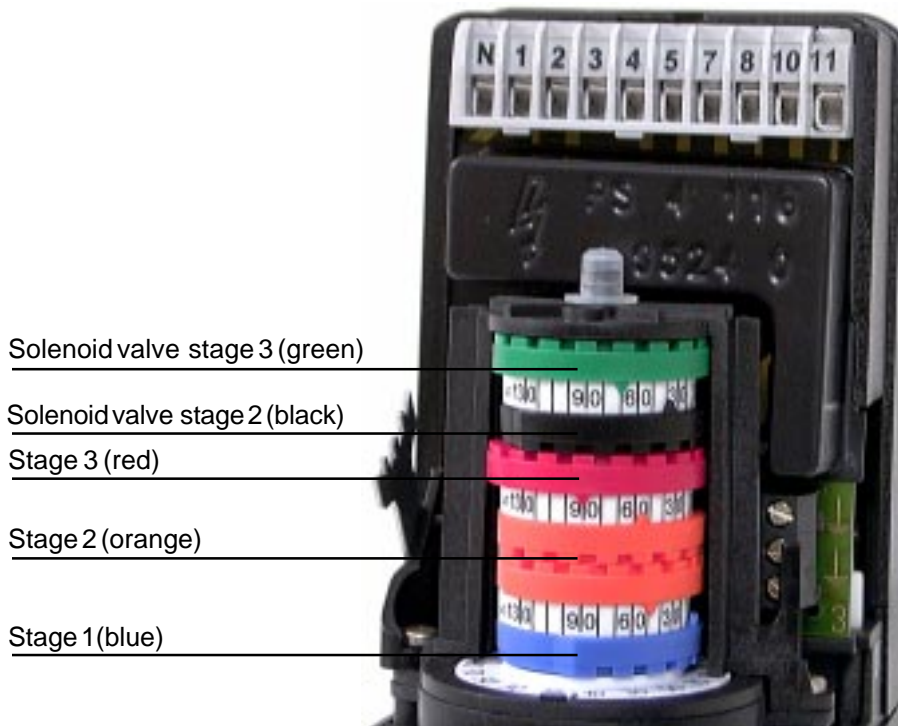

Stage 1:

Adjust the operating switch to stage 2 (II).

- * Reduce the air volume:
Turn blue cam towards 0°.
- * Increase the air volume:
Turn blue cam towards 90°.

Adjust the operating switch back to stage 1 and check.

Stage 2:

Adjust the operating switch to stage 1 (I).

- * Reduce the air volume:
Turn orange cam towards 0°.
- * Increase the air volume:
Turn orange cam towards 90°.

Adjust the operating switch back to stage 2 and ensure that the correct air volume has been obtained.

Stage 3:

Adjust the operating switch to stage 2 (II).

- * Reduce the air volume:
Turn red cam towards 0°.
- * Increase the air volume:
Turn red cam towards 90°.

Adjust the operating switch to stage 3 (III) and ensure that the correct air volume has been obtained.

NOTE

On adjustment of stage 2 and stage 3 the black cam (Mv2) must be within the settings of the blue and orange cams and the green cam (Mv3) within the settings of the orange and the red cams.

MAINTENANCE OF OIL BURNER

Warning: Before doing any service switch off power at the main switch and cut off the oil supply.

SERVICE OF BURNER HEAD

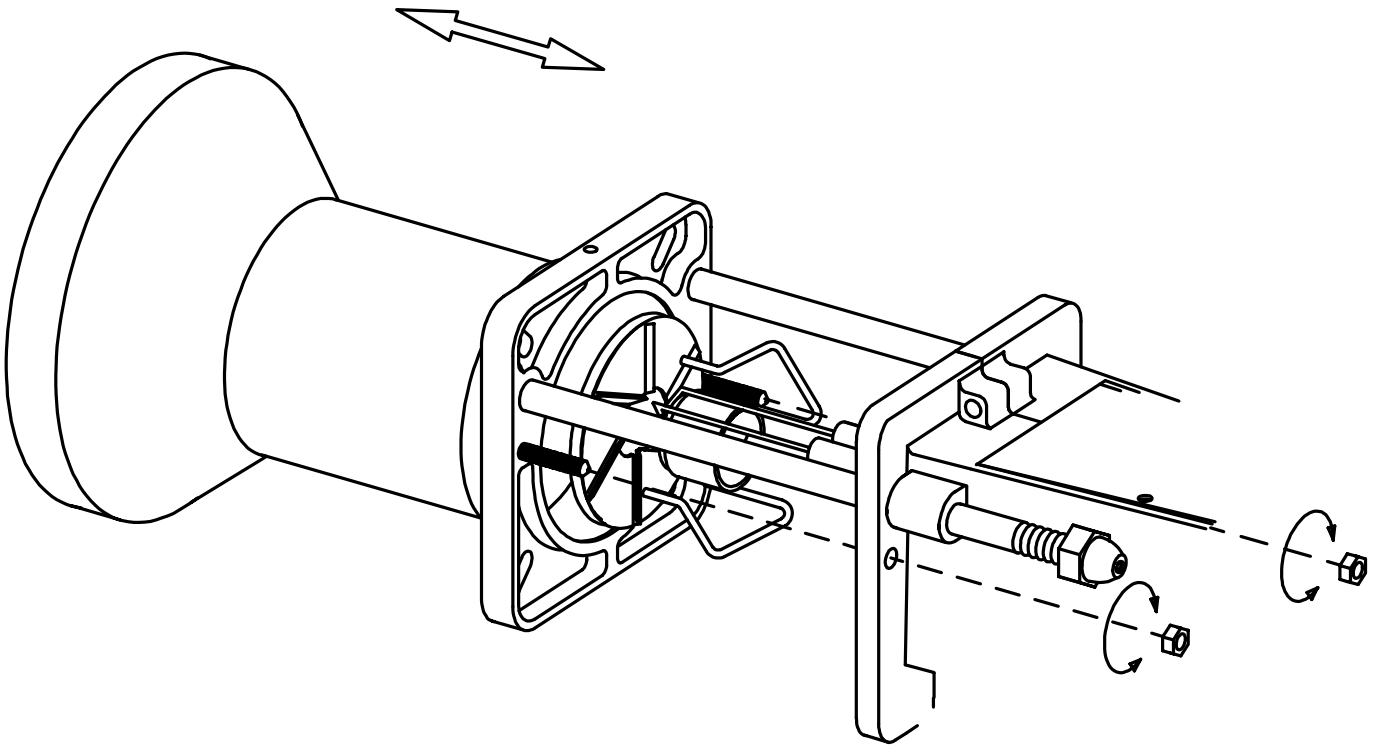

NOTE!

For maintenance of the brake plate, nozzles, electrodes etc, when using a long design of the burner tube, you have to **remove the nozzle assembly from the connecting pipe and move the assembly backwards** in the fan housing (from the boiler).

ELECTRIC EQUIPMENT

OIL BURNER CONTROL: LAL1...

WIRING DIAGRAM

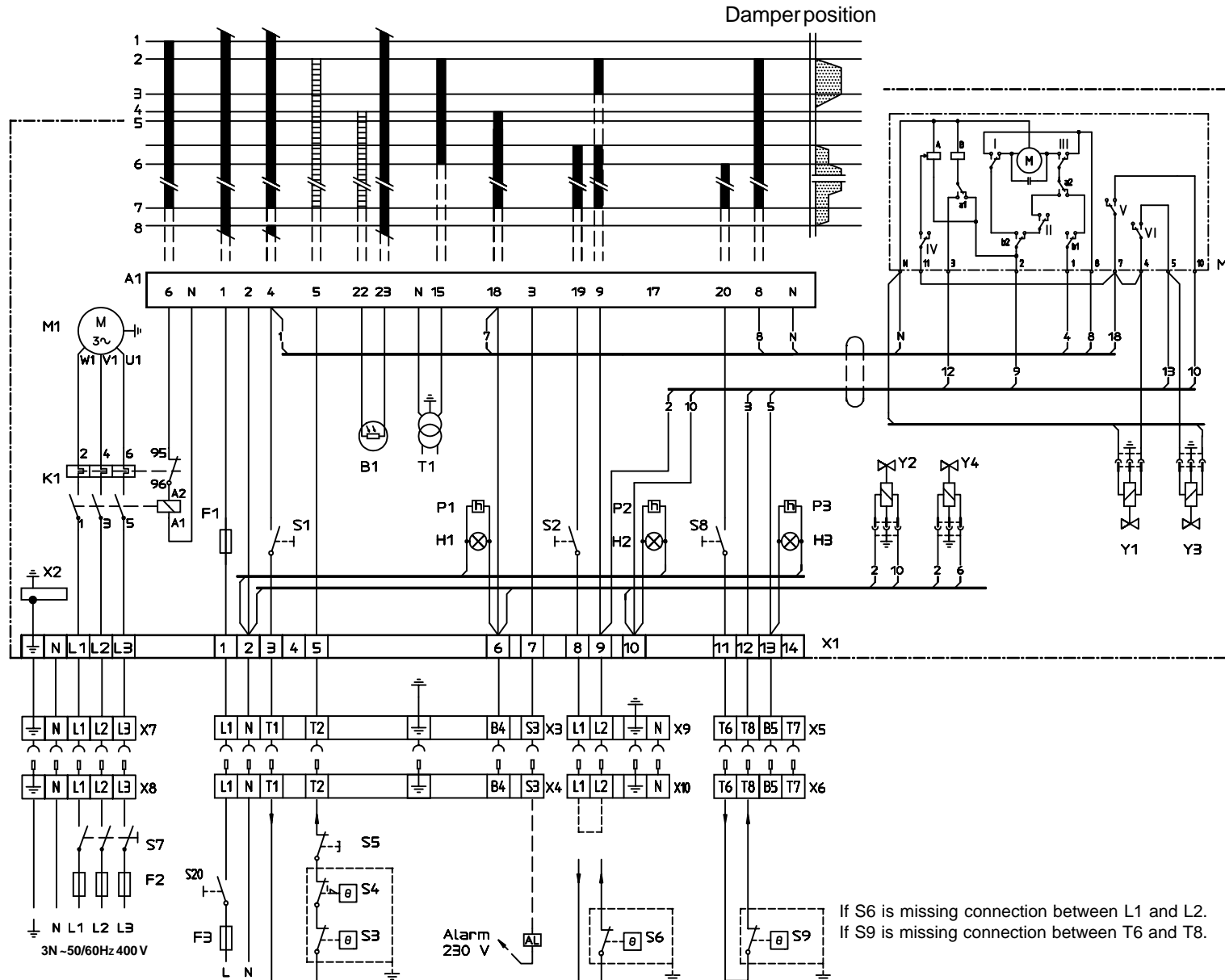

LIST OF COMPONENTS

- A1 Oil burner control
- B1 Photoresistor
- F1 Operating fuse
- F2 Fuse
- F3 Fuse
- H1 Lamp, Stage 1
- H2 Lamp, Stage 2
- H3 Lamp, Stage 3
- K1 Thermal overload protection
- M1 Burner motor
- M2 Damper motor L&S SQN75.436A21B
- P1 Time meter, Stage 1
- P2 Time meter, Stage 2
- P3 Time meter, Stage 3
- S1 Operating switch
- S2 Operating switch, Stage 2
- S3 Control thermostat
- S4 Temperature limiter
- S5 Micro switch for hinged door
- S6 Control thermostat, Stage 2
- S7 Main switch
- S8 Operating switch, Stage 3
- S9 Control thermostat, Stage 3
- S20 Main switch
- T1 Ignition transformer
- X1 Connection terminal board
- X2 Earth terminal
- X3 Plug-in contact "Euro", burner
- X4 Plug-in contact "Euro", boiler
- X5 Plug-in contact "Euro", stage 3 burner
- X6 Plug-in contact "Euro", stage 3 boiler
- X7 Plug-in contact "Euro" 3-phase, burner
- X8 Plug-in contact "Euro", 3-phase, boiler
- X9 Plug-in contact "Euro", stage 2 burner
- X10 Plug-in contact "Euro", stage 2 boiler
- Y1 Solenoid valve 1
- Y2 Solenoid valve 2
- Y3 Solenoid valve 3
- Y4 Safety solenoid valve

If S6 is missing connection between L1 and L2.
If S9 is missing connection between T6 and T8.

Mains connection and fuse in accordance with local regulations.

ELECTRIC EQUIPMENT

OIL BURNER CONTROL: LAL1...

FUNCTION

1. Operating switch ON, twin thermostat ON Air damper closed
The burner motor starts.
2. Ignition spark is formed
Ignition spark is formed. Air damper motor opens the damper to stage 3.
3. Air damper motor closes
The air damper motor closes to stage 1.
4. Solenoid valve 1 opens
The oil mist is ignited. The photoresistor indicates a flame.
5. The safety time expires
 - a. If there is no flame established **before** this time limit the burner control locks out.
 - b. If the flame for some reason disappears **after** this time limit the burner control also locks out. If a repetition of the start-up sequence is desired, the wire link marked "Repetition" on the side of the base plate of the control must be removed.
6. Thermostat and switch Stage 2 ON
The burner can now change over to stage 2.
7. Thermostat and switch Stage 3 ON
The burner can now change over to stage 3.
- 8-9. Operating position
The burner can now change between stage 1, 2 and 3. The burner operation is interrupted by means of the operating switch or the thermostat.

The control locks out

A red lamp in the control is lit. Move the transparent cover aside and restart the burner by pressing the reset button.

Note! In the window of the control symbols appear showing in which position the control locks out, see the adjoining explanation.

TECHNICAL DATA

Pre-ignition time:	from start
Pre-purge time with full air volume:	22 s
Safety time:	5 s
Post-ignition time:	15 s
Interval between Mv1 and Mv2:	7,5 s
Reset after lock-out:	Immediately
Time of re-start:	47 s
Ambient temperature:	- 20 to + 60°C
Min. required current at 220 V and	95/105 µ A
Max. current:	160 µ A
Protective standard:	IP40

CONTROL PROGRAMME UNDER FAULT CONDITIONS AND LOCK-OUT INDICATION

In the event of fault conditions the sequence switch stops and simultaneously the lock-out indicator. The symbol appearing above the reading mark indicates kind of fault:

- ◀ **No start**, because e.g., the CLOSE signal has not been supplied to terminal 8 by the limit switch, or a contact has not been closed between terminals 4 and 5.
- ▲ **Shut-down of start-up sequence**, because the OPEN signal has not been supplied to terminal 8 by the limit switch. Terminals 6, 7 and 15 remain under voltage until the fault is corrected.
- **Lock-out** due to a fault in the supervision circuit.
- ▼ **Shut-down of start-up sequence**, because the position signal for the low-flame position has not been supplied to terminal 8 by the auxiliary switch. Terminals 6, 7 and 15 remain under voltage until the fault is corrected.
- 1 **Lock-out**, because no flame signal has been received on completion of the safety time.
- | **Lock-out**, because the flame signal has been lost during burner operation or air pressure failure has occurred.
- ◀ **Lock-out on completion or after completion of control programme sequence** due to extraneous light (e.g. flame not extinguished, leaking fuel valves) or due to a faulty flame signal (e.g. fault in flame supervision circuit or similar).

- a - b Start-up sequence
- b - b' "idle steps" up to the self shut-down of the sequence switch
- b (b') - a Post-purge sequence

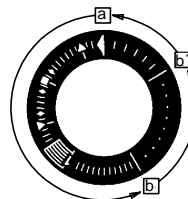

INSTRUCTIONS PUMP TYPE DANFOSS RSA 125

TECHNICAL DATA

Viscosity range: 1,3-18,0 mm²/s
 Pressure range: 12,0-21,0 bar
 Oil temperature: -10 to +70°C

COMPONENTS

1. Pressure gauge port G 1/8"
2. Nozzle port G 1/8"
3. Suction line G 1/4"
4. Suction line G 1/4"
5. Return line G 1/4"
6. Return line R 1/4"
7. By-pass plug
8. Pressure adjustment, 4 mm allen key

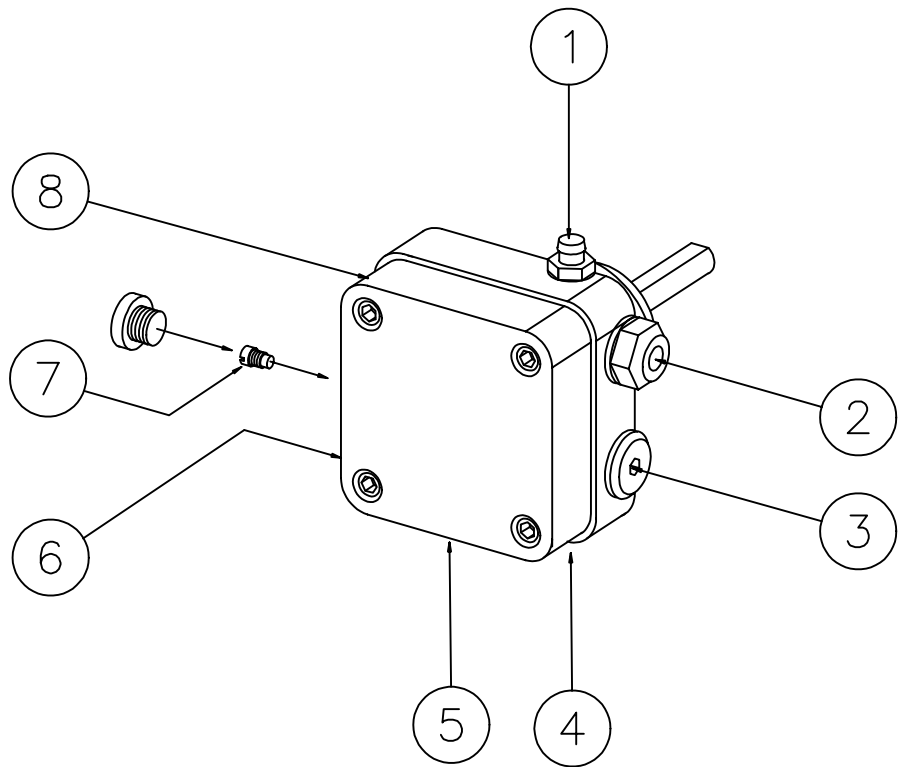

SUCTION LINE TABLES

The suction line tables consist of theoretically calculated values where the pipe dimensions and oil velocity have been matched so that turbulences will not occur. Such turbulences will result in increased pressure losses and in acoustic noise in the pipe system. In addition to drawn copper piping a pipe system usually comprises 4 elbows, a non-return valve, a cut-off valve and an external oil filter.

The sum of these individual resistances is so insignificant that they can be disregarded. The tables do not include any lengths exceeding 100 m as experience shows that longer lengths are not needed.

The tables apply to a standard fuel oil of normal commercial quality according to current standards. On commissioning with an empty tube system the oil pump should not be run without oil for more than 5 min. (a condition is that the pump is being lubricated during operation).

The tables state the total suction line length in metres at a viscosity of 6,0 mm²/s.

PURGING

On 1-pipe systems it is necessary to purge the pump. On 2-pipe systems purging is automatic through the return line.

1-pipe system		1-pipe system	
Height	Pipe diameter	Height	Pipe diameter
H	ø10mm ø12mm ø15mm ø20mm	H	ø10mm ø12mm ø15mm ø20mm
m	m m m m	m	m m m m
With an overlying tank a 1-pipe-system is not recommended		With an underlying tank a 1-pipe-system is not recommended	
Two-pipe system		Two-pipe system	
Height	Pipe diameter	Height	Pipe diameter
H	ø10mm ø12mm ø15mm ø20mm	H	ø10mm ø12mm ø15mm ø20mm
m	m m m m	m	m m m m
4,0	39 81 100 100	0	20 41 100 100
3,5	36 76 100 100	-0,5	18 36 89 100
3,0	34 71 100 100	-1,0	15 31 77 100
2,5	32 66 100 100	-1,5	13 26 65 100
2,0	29 61 100 100	-2,0	10 22 53 100
1,5	27 56 100 100	-2,5	8 17 41 100
1,0	25 51 100 100	-3,0	6 12 29 91
0,5	22 46 100 100	-3,5	3 7 17 53
		-4,0	1 2 5 15

FUNCTION DANFOSS

RSA 95 - 125

When the pump is started oil is drawn through the suction port "S" via filter "H" to the suction side of the gearwheel set "C". From here the gearwheel set pumps the oil to the pressure side and at the same time the oil becomes pressurized. The oil is led to cut-off and regulating valve "V" which opens when the set pressure is reached.

The pressure is controlled and kept constant by regulating valve "V". At the same time the gearwheel set "C" distributes the oil through nozzle port "P" and pump return side "R" via the shaft seal "F".

The quantity of oil supplied to nozzle port "P" is determined by the pressure set on regulating valve "V" and the nozzle/resistance in the nozzle line.

In 2-pipe-systems excess oil is led back to the oil tank. In 1-pipe-systems the by-pass plug "A" must be removed to give free flow back to the suction side via return line "G" with return port "R" closed.

When the pump is stopped, the pump

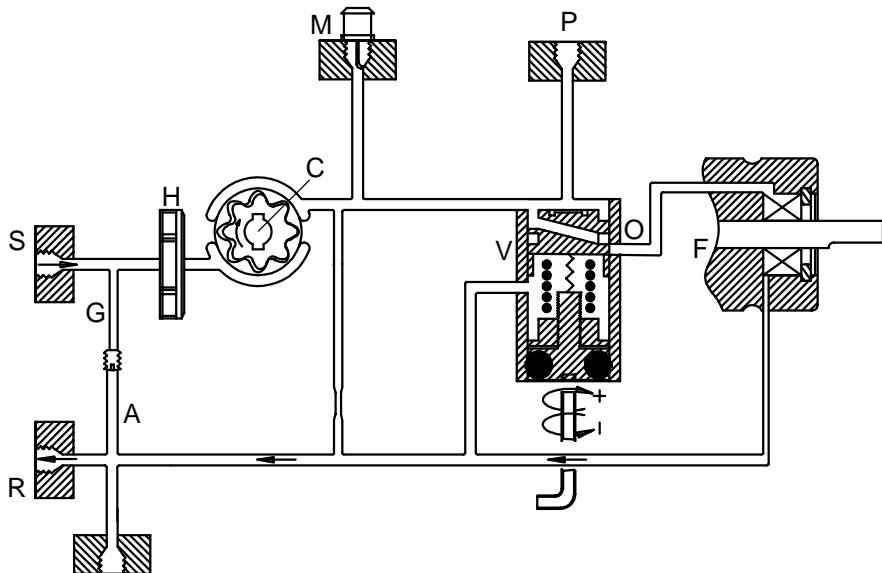

output drops and produces a drop in the oil pressure. The spring in the regulating valve presses the regulating piston forward until it seals in port "P". This cuts off the oil flow to the nozzle and ensures that the nozzle line is effectively shut off.

If the pump is overloaded, i.e. more oil is demanded than the gearwheel is able to pump under the given conditions, the oil pressure falls below

the set value because the piston of the regulating valve moves towards its closed position and partially or wholly cuts off the return oil via port "O".

This can be remedied by

- reducing the pump pressure
- reducing the capacity, i.e. smaller nozzle or greater resistance
- changing to a pump with higher capacity

MOUNTING/DISMOUNTING BY-PASS PLUG

In a 2-pipe-system excess oil is led back direct to the oil tank. In a 1-pipe-system the by-pass plug must be removed so that there is a free passage back to the suction side through the return line with the return port closed.

One pipe system

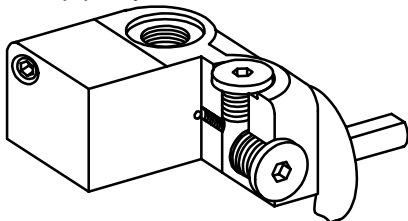

Two pipe system

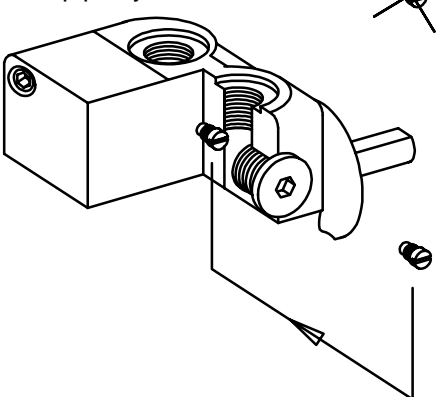

EXCHANGE OF FILTER

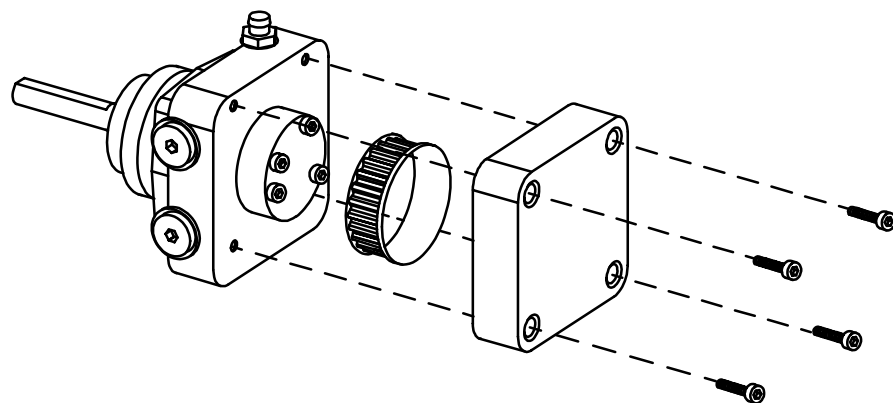

FUNCTION FOR DANFOSS RSA

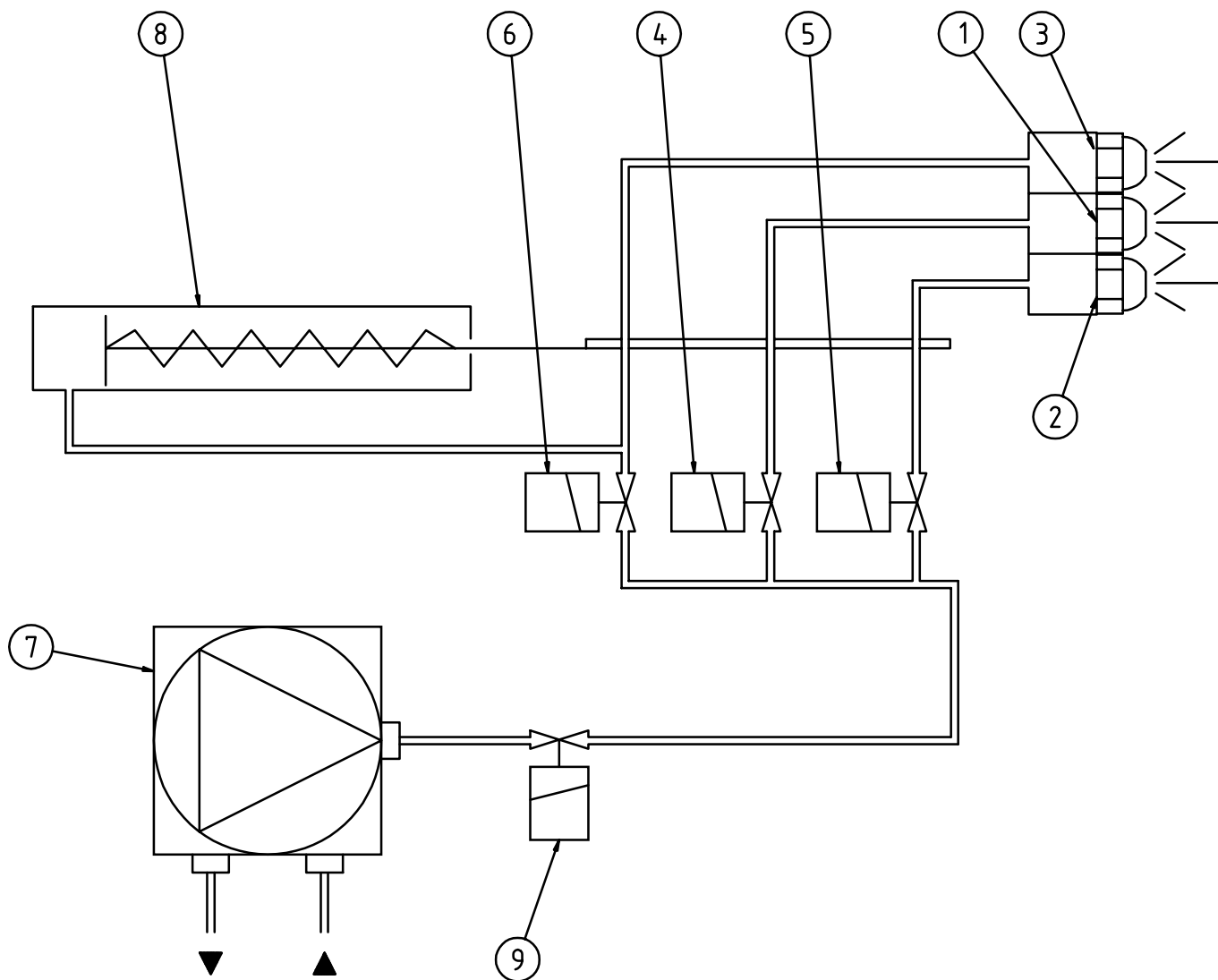

- 1. Nozzle Stage 1
- 2. Nozzle Stage 2
- 3. Nozzle Stage 3
- 4. Solenoid valve Stage 1
- 5. Solenoid valve Stage 2
- 6. Solenoid valve Stage 3
and adjustment device nozzle
assembly
- 7. Oilpump
- 8. Adjustment device nozzle
assembly
- 9. Safety solenoid valve

NOZZLE TABLE

Pump pressure bar

Gph	10			11			12			13			14			15			16			17		
	kg/h	kW	Mcal/h	kg/h	kW	Mcal/h	kg/h	kW	Mcal/h	kg/h	kW	Mcal/h	kg/h	kW	Mcal/h	kg/h	kW	Mcal/h	kg/h	kW	Mcal/h	kg/h	kW	Mcal/h
1,00	3,72	44	38	3,90	46	40	4,08	48	42	4,24	50	43	4,40	52	45	4,56	54	46	4,71	56	48	4,85	57	49
1,10	4,09	48	42	4,29	51	44	4,48	53	46	4,67	55	48	4,84	57	49	5,01	59	51	5,18	61	53	5,34	63	54
1,20	4,47	53	46	4,68	55	48	4,89	58	50	5,09	60	52	5,29	63	54	5,47	65	56	5,65	67	58	5,82	69	59
1,25	4,65	55	47	4,88	58	50	5,10	60	52	5,30	63	54	5,51	65	56	5,70	68	58	5,89	70	60	6,07	72	62
1,35	5,02	59	51	5,27	62	54	5,50	65	56	5,73	68	58	5,95	70	61	6,15	73	63	6,36	75	65	6,55	78	67
1,50	5,58	66	57	5,85	69	60	6,11	72	62	6,36	75	65	6,60	78	67	6,83	81	70	7,06	84	72	7,27	86	74
1,65	6,14	73	63	6,44	76	66	6,73	80	69	7,00	83	71	7,27	86	74	7,52	89	77	7,77	92	79	8,01	95	82
1,75	6,51	77	66	6,83	81	70	7,14	85	73	7,42	88	76	7,71	91	79	7,97	95	81	8,24	98	84	8,49	101	87
2,00	7,45	88	76	7,81	93	80	8,16	97	83	8,49	101	87	8,81	104	90	9,12	108	93	9,42	112	96	9,71	115	99
2,25	8,38	99	85	8,78	104	90	9,18	109	94	9,55	113	97	9,91	118	101	10,26	122	105	10,60	126	108	10,92	130	111
2,50	9,31	110	95	9,76	116	100	10,19	121	104	10,61	126	108	11,01	131	112	11,39	135	116	11,77	140	120	12,13	144	124
2,75	10,24	121	104	10,73	127	109	11,21	133	114	11,67	138	119	12,11	144	123	12,53	149	128	12,95	154	132	13,35	158	136
3,00	11,16	132	114	11,71	139	119	12,23	145	125	12,73	151	130	13,21	157	135	13,67	162	139	14,13	168	144	14,56	173	148
3,50	13,03	154	133	13,66	162	139	14,27	169	146	14,85	176	151	15,42	183	157	15,95	189	163	16,49	196	168	16,99	201	173
4,00	14,89	176	152	15,62	185	159	16,31	193	166	16,97	201	173	17,62	209	180	18,23	216	186	18,84	223	192	19,42	230	198
4,50	16,75	199	171	17,57	208	179	18,35	218	187	19,10	226	195	19,82	235	202	20,51	243	209	21,20	251	216	21,84	259	223
5,00	18,62	220	190	19,52	231	199	20,39	242	208	21,22	252	216	22,03	261	225	22,79	270	232	23,55	279	240	24,27	288	247
5,50	20,48	243	209	21,47	255	219	22,43	266	229	23,34	277	238	24,23	287	247	25,07	297	256	25,91	307	264	26,70	317	272
6,00	22,34	265	228	23,42	278	239	24,47	290	250	25,46	302	260	26,43	313	270	27,49	326	280	28,27	335	288	29,13	345	297
6,50	24,20	287	247	25,37	301	259	26,51	314	270	27,58	327	281	28,63	340	292	29,63	351	302	30,62	363	312	31,55	374	322
7,00	26,06	309	266	27,33	324	279	28,55	339	291	29,70	352	303	30,84	366	314	31,91	378	325	32,98	391	336	33,98	403	347
7,50	27,92	331	285	29,28	347	299	30,59	363	312	31,83	377	325	3,04	392	337	34,19	405	349	35,33	419	360	36,41	432	371
8,00	29,79	353	304	31,23	370	318	32,63	387	333	33,95	403	346	35,25	418	359	36,47	433	372	37,69	447	384	38,80	460	396
8,50	31,65	375	323	33,18	393	338	34,66	411	353	36,07	428	368	37,45	444	382	38,74	459	395	40,04	475	408	41,26	489	421
9,00	33,59	398	343	35,14	417	358	36,71	435	374	38,19	453	389	39,65	470	404	41,02	486	418	42,40	503	432	43,69	518	446
9,50	35,37	419	361	37,09	440	378	38,74	459	395	40,31	478	411	41,85	496	427	43,30	514	442	44,75	531	456	46,11	547	470
10,00	37,23	441	380	39,04	463	398	40,78	484	416	42,44	503	433	44,06	523	449	45,58	541	465	47,11	559	480	47,11	559	480
11,00	40,96	486	418	42,94	509	438	44,86	532	457	46,68	554	476	48,46	575	494	50,14	595	511	51,82	615	528	53,40	633	545
12,00	44,68	530	456	46,85	556	478	48,94	580	499	50,92	604	519	52,87	627	539	54,70	648	558	56,53	670	576	58,25	691	594
14,00	52,12	618	531	54,65	648	557	57,10	677	582	59,41	705	606	62,68	732	629	63,81	757	651	65,95	778	669	67,96	806	693
16,00	59,57	706	607	62,46	741	637	65,26	774	666	67,90	805	692	70,49	836	719	72,93	865	744	75,38	894	769	77,67	921	792
18,00	67,02	795	683	70,27	833	717	73,41	871	749	76,39	906	779	79,30	940	809	82,05	973	837	84,80	1006	865	87,38	1036	891
20,00	74,47	883	759	78,08	926	796	81,57	967	832	84,87	1007	865	88,11	1045	899	91,17	1081	930	94,22	1117	961	97,09	1151	990
22,00	81,91	971	835	85,89	1019	876	89,73	1064	915	93,36	1107	952	96,92	1149	988	100,28	1189	1023	103,64	1229	1057	106,79	1267	1089
24,00	89,36	1060	911	93,70	1111	956	97,88	1161	998	101,85	1208	1039	105,74	1254	1078	109,40	1297	1116	113,06	1341	1153	116,50	1382	1188
26,00	96,81	1148	987	101,50	1204	1035	106,04	1258	1081	110,33	1308	1125	114,55	1359	1168	118,52	1406	1209	122,49	1453	1249	126,21	1497	1287

The table applies to oil with a viscosity of 4,4 mm²/s (cSt) with density 830 kg/m³.

FAULT LOCATION

BURNER FAILS TO START

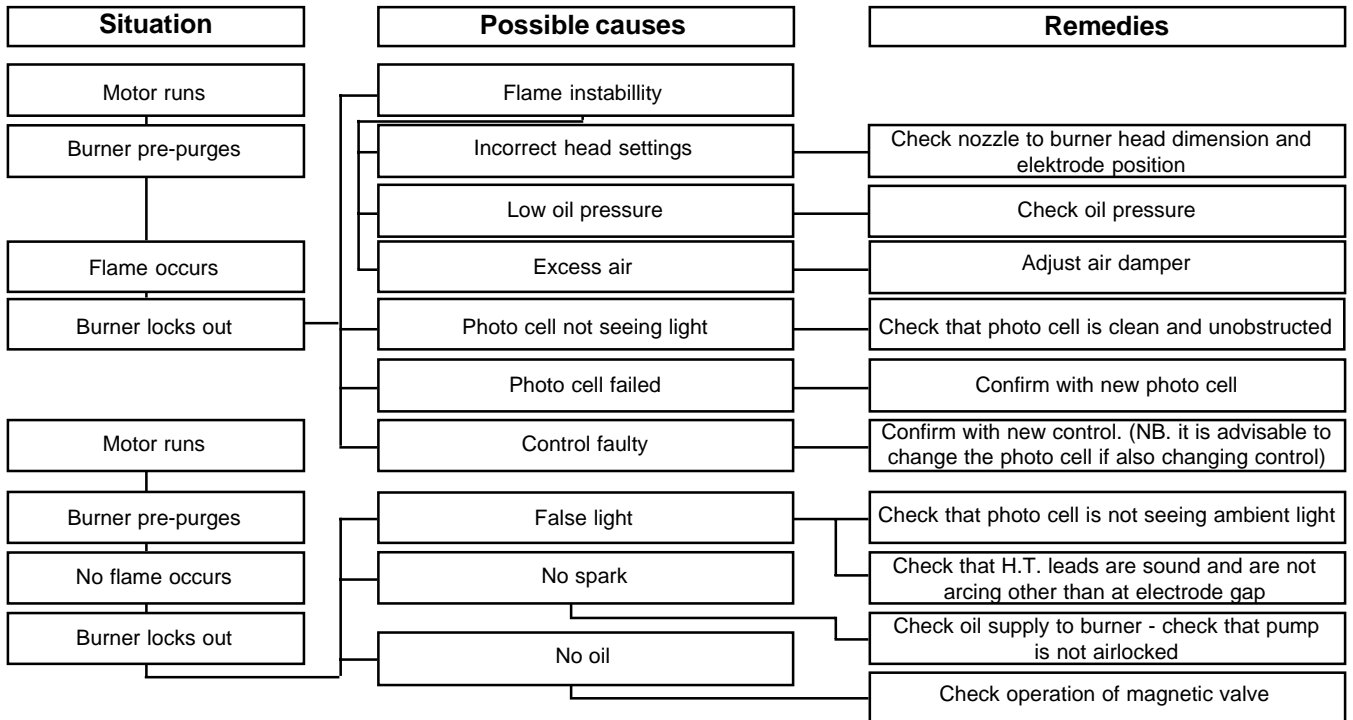

BURNER FAILS TO START AFTER NORMAL OPERATION

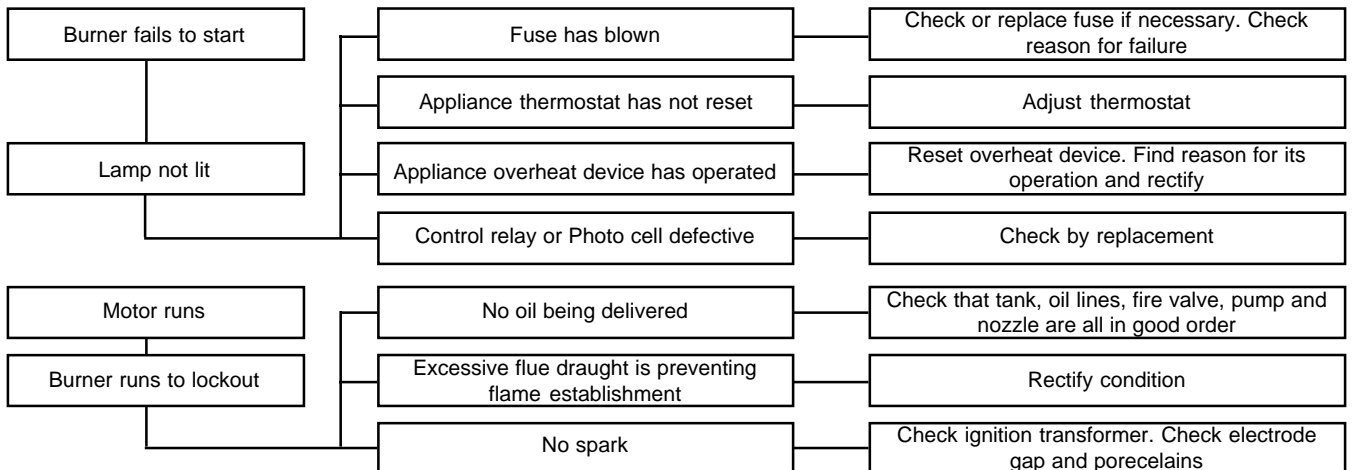

DELAYED IGNITION, BURNERS STARTS VIOLENTLY

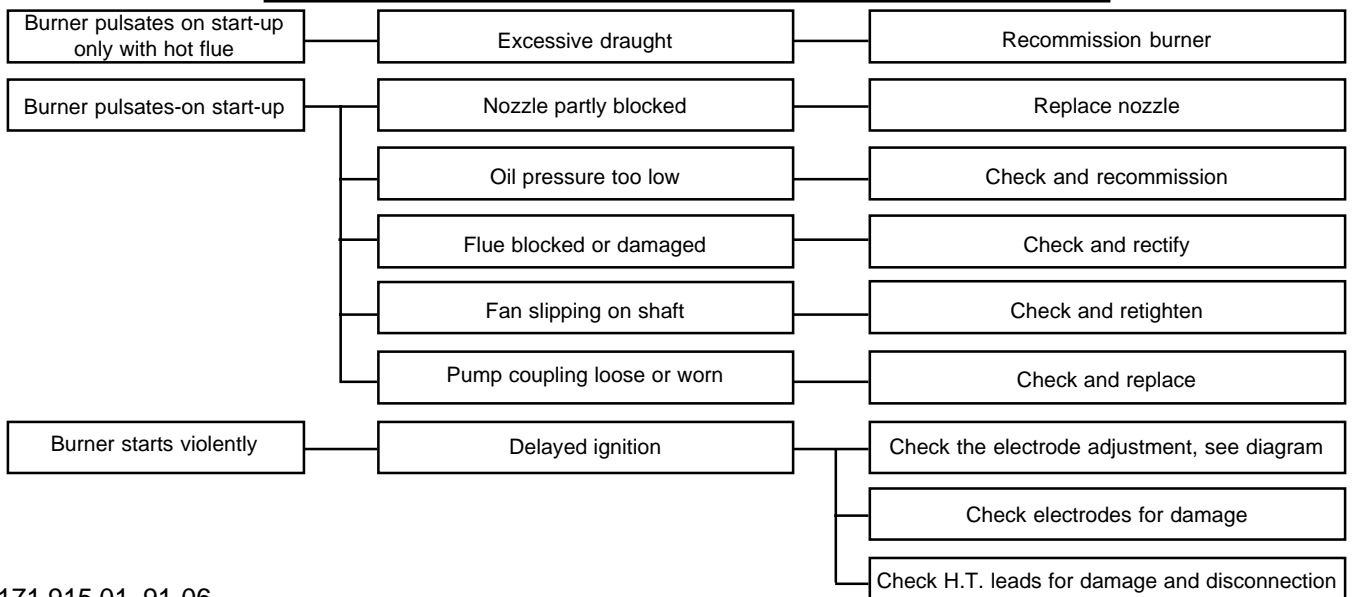

DECLARATION OF CONFORMITY

We
(supplier's name)

BENTONE AB

(address)

P.O. Box 309, S-341 26 Ljungby, Sverige

declare under our sole responsibility that the product
(name, type or model, batch or serial number, possibly sources and number of items)

ST 97, ST 108, ST 120, ST 133, ST 146, B 9, B 10, B 11, B 20, B 30, B 40, B 45, B 50, B 60, B 70, B 80, SF 141

and TF 205, fan burners for gasoil

to which this declaration relates is in conformity with the following standard(s) or the normative document(s)
(title and/or number and date of issue of the standard(s) or other normative document(s))

DIN 4787 and EN 267

following the provisions of Directive
(if applicable)

EMC directive 89 / 336 / EEC, Low voltage directive 73 / 23 / EEC and Machinery directive 89/392/EEC.

Re. the Efficiency directive 92/42/EEC, please see the next page.

Ljungby, 25th May, 1999

(Place and date of issue)

BENTONE AB

Ulf Bondeson

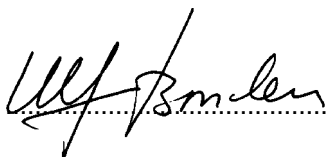

(name and signature of equivalent marking of authorized person)

To fulfil the demands according to the Efficiency directive 92/42/EEC, Article 2, we herewith state the following parameters.

Burner type	Capacity kg/h (kW)	Test report No. TÜV	Pressure in combustion chamber mbar	Product ID-No. as per EC-Type Examination Certificate
ST 97	1,2-2,6 (14,2-30,8)	3728 (15.03.96)	-0,2 to+1,4 to + 0,1	CE 0036 0128/98
ST 108	1,2-3,8 (14,2-45)	3729 (15.03.96)	-0,2 to + 1,4 to + 0,2	CE 0036 0129/98
ST 120	2,1-4,5 (24,9-53,3)	3581 (10.11.94)	-0,2 to + 1,9 to + 0,2	CE 0036 0130/98
ST 133	2,0-10,0 (23,7-118,5)	3795 (12.11.96)	-0,2 to + 2,2 to + 0,1	CE 0036 0131/98
ST 146	4,0-10,0 (47,4-118,5)	3796 (12.11.96)	-0,2 to + 3,9 to + 0,1	CE 0036 0132/98
B 9	1,2-2,5 (14,2-29,6)	3341 (21.08.92)	-0,2 to + 0,8 to + 0,1	CE 0036 0133/98
B 10	1,4-3,0 (16,6-35,6)	3465 (03.09.93)	-0,2 to + 1,1 to + 0,25	CE 0036 0134/98
B 10KA	2,0-4,6 (23,7-54,5)	3778 (18.10.96)	-0,2 to + 0,95 to + 0,1	CE 0036 0135/98
B 10ZHV	1,2-2,5 (14,2-29,5)	3525 (21.01.94)	-0,2 to + 1,0 to + 0,3	CE 0036 0136/98
B 11				
B 20K	4,3-9,8 (51,0-116,1)	3779 (18.10.96)	-0,2 to + 1,15 to + 0,1	CE 0036 0137/98
B 20KA	2,0-8,0 (23,7-94,8)	3333 (04.08.92)	-0,2 to 0,78 to + 0,1	CE 0036 0138/98
B 20ZHV	2,1-4,3 (24,9-51,0)	3397 (14-06.93)	-0,2 to 1,25 to + 0,1	CE 0036 0139/98
B 30	6,0-17,5 (71,1-207,4)	3524 (24.01.94)	-0,2 to + 2,8 to + 0,2	CE 0036 0140/98
B 30A	6,0-17,0 (71,1-207,4)	3797 (12.11.96)	-0,2 to + 3,0 to + 0,1	CE 0036 0141/98
B 30A2	4,5-15,0 (53,3-177,8)	3798 (12.11.96)	-0,2 to 3,8 to + 0,1	CE 0036 0142/98
B 30ZHV-2	3,3-10,0 (39,1-118,5)	3563 (10.11.94)	-0,2 to + 1,3 to + 0,1	CE 0036 0143/98
B 40	9,0-29,5 (106,7-349,6)	3503 (21.09.93)	-0,3 to + 4,1 to + 0,2	CE 0036 0144/98
B 40A	9,0-29,5 (106,7-349,6)	3799 (12.11.96)	-0,2 to + 5,3 to + 0,1	CE 0036 0145/98

To fulfil the demands according to the Efficiency directive 92/42/EEC, Article 2, we herewith state the following parameters.

Burner type	Capacity kg/h (kW)	Test report No. TÜV	Pressure in combustion chamber mbar	Product ID-No. as per EC-Type Examination Certificate
B 50-2F	12,0-59,0 (142,2-699,2)	3390 (09.06.93)	-0,2 to +9,4 to + 0,2	CE 0036 0147/98
B 50-3F	12,0-59,0 (142,2-699,2)	3592 (10.11.94)	-0,2 to + 9,25 to + 0,1	CE 0036 0148/98
B 60-2F	20,0-90,0 (237,0-1066,5)	3466 (03.09.93)	-0,3 to + 11,4 to + 0,8	CE 0036 0149/98
B 60-3F	20,0-90,0 (237,0-1066,5)	3591 (10.11.94)	-0,3 to + 11,4 to + 0,8	CE 0036 0150/98
B 70				
B 80				
SF 141-3	50,0-140,0 (592,5-1659,0)	3502 (16.09.93)	-0,7 to 8,7 to + 12,0 to + 0,1	CE 0036 0151/98
TF 205-3	70,0-205,0	3501 (16.09.93)	-0,7 to + 14,0 to + 16,0 to + 0,1	CE 0036 0152/98
B45A	8,5-47,0 (100,8-557,5)	3977 (16.04.99)	-0,1 to + 0,4 to + 7,0	CE 0036 0250/99
B45A2	8,5-45,5 (100,8-539,7)	3978 (16.04.99)	-0,1 to + 0,4 to + 7,5	CE 0036 0251/99