

STARJET

Open-Fired Multi-Fuel Burner

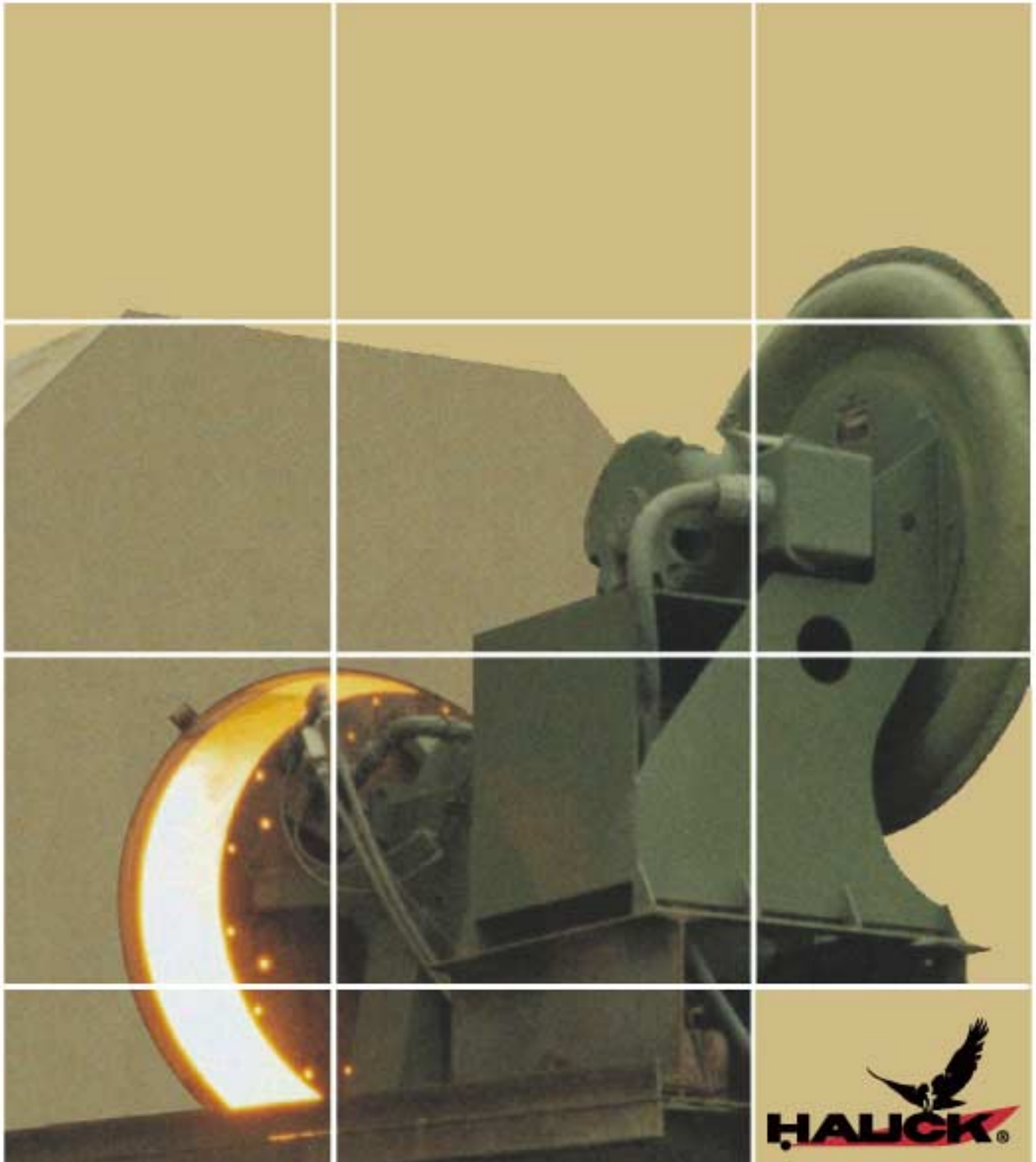

STARJET



Flame shaping is achieved by moving the adjustment lever at the side of the burner. This lever is directly linked to the adjustable spin vanes. This feature greatly reduces setup time at initial start-up or whenever the plant is relocated, and permits fine-tuning when mix changes require a change in flame shape and intensity. The operator can ensure that flame shape and intensity are always optimal because fine-tuning can be accomplished in minutes instead of hours.

StarJet fuel manifolds and air systems conform to the standards of the National Fire Protection Association (NFPA). The StarJet burner is fitted with automatic valving and controls to allow for full flame supervision and optimum compatibility with Hauck combustion control systems. Specifically designed for asphalt plants, these control systems are described in separate data sheets.

ADVANTAGES

- No ignition tile
- No combustion chamber required
- Convenient flame shaping
- Wide turndown
- Compressed air not required
- Fuels fired:
 - Heavy Fuel Oil*
 - Light Fuel Oil
 - Natural Gas
 - Liquid LP Gas
 - Landfill Gas

The StarJet continues Hauck's longstanding reputation for providing efficient and durable burners for the asphalt industry. The burner is designed to recirculate the hot gases, providing flame stability over its wide operating range. This eliminates the need for refractory ignition tile and combustion chamber. The StarJet can have the short, bushy flame for drum mixing (and particularly required for recycling) or a long flame depending on the application. The burner's wide turndown is particularly useful when lower production rates are desired, such as when making cold patch material.

*Heavy and waste fuel oils require heating and filtration. 90 SSU or less viscosity required.

The StarJet fires all commercial grades of fuel oil, natural gas or LP gas. As a combination burner, the StarJet will burn any two fuels in combination with the exception of LP gas in the liquid state and fuel oil. When these two fuel combinations are desired, it is necessary to specify the primary fuel and purchase the separate atomizer set assembly for the standby fuel.

The StarJet also provides greater flexibility in mounting a burner/blower combination on dryer frames in confined spaces. This mounting flexibility is achieved by a 45° air entry available at the 3, 6, 9, or 12 o'clock position, providing a wide range of burner/blower angle arrangements. The burner air inlet is the same diameter as the Hauck Turbo Blower outlet. Hauck's line of standard and high pressure direct-drive blowers matched to the StarJet burner simplifies installation.



StarJet Burner with a prepiped oil manifold.

STARJET

FEATURES THAT DELIVER FUEL EFFICIENCY AND IMPROVED PRODUCTION PERFORMANCE

High Intensity Flame

Hauck's proven experience in the asphalt industry clearly shows that combustion volume intensity is the key to burner performance. The StarJet was designed to maximize flame intensity and deliver a quick heat release. Combustion is completed in a much shorter space than that of any other burner on the market today. This minimizes flame quenching by the aggregate and allows more space in the dryer for material vailing, thus improving production performance and fuel efficiency.

High Pressure Blowers

Hauck's 36 ounce blowers deliver superior fuel atomization and combustion intensity. Atomizing air is supplied by the burner blower.

Flame Shaping

The StarJet allows flame shaping to tailor the flame shape to the requirements of any drum through adjustment of the spin vanes. A single adjustment lever changes the angle of the spin vanes in the secondary air passage. The flame is easily adaptable from a short bushy flame to a long, narrow pencil flame. The plant operator can change the flame shape in a matter of minutes. The change from a virgin mix to a recycle mix is a simple process. For the first time, there is a burner designed for all applications: batch plant drums, drum mixers, and drum mixers with recycle.



SHORT FLAME OIL



LONG FLAME OIL



SHORT FLAME GAS



LONG FLAME GAS



SHORT FLAME L.P.



LONG FLAME L.P.

Flame shaping on all fuels permit matching the StarJet flame to most rotary dryers.

STARJET

THE HAUCK STARJET AND COMBUSTION FOR ASPHALT PRODUCTION



Natural Gas and LP

As is true of the oil flame, both the LP flame and the natural gas flame have maximum flame intensity and a rapid heat release. This ensures improved fuel efficiency and production performance. In addition, the new constant pressure LP system available from Hauck provides better temperature control and a wider turndown (7:1 or more) than ever achieved before. Whatever your fuel requirements are, the StarJet is your best combustion choice.

StarJet Burner

Hauck has designed the StarJet with an internal zone of hot recirculating gases. This assures burner flame stability. Combustion can be completed in a much shorter space with an intense bushy flame ideal for drum mixing— or with a long flame depending on the application. With a properly designed combustion zone within the dryer, the StarJet provides the most efficient heat transfer to the material.

Superior Oil Atomization

The StarJet is capable of burning a complete range of available fuel oils including heavy oils and waste oils. The unique 'Swirl Generator' oil nozzle efficiently atomizes even the most difficult heavy oil and waste oil. As evidenced in the photograph above, the 'Star' shaped atomization pattern is clearly evident. Low pressure oil and blower air are mixed in the nozzle and create a vaporized fuel mist. The swirl generator causes rapid combustion resulting in a flame that is low pressure center stabilized.

The StarJet, with all of its outstanding features, is the best open-fired combustion system on the market today. It burns light and heavy fuel oils, waste oils, natural gas, and LP.

Combustion Flights

Combustion flights are a means of providing a volume within the drum for the combustion process to take place without being quenched by the material to be dried. They also help divert material flow along the drum shell to reduce shell temperatures. Shell temperatures are a function of:

1. available combustion volume for the required heat input
2. the density of the material vail downstream
3. the required material outlet temperature
4. the design of the material flow through the combustion zone.

Hauck recommends that combustion flights be sized to provide a solution for two of the four parameters—combustion volume and material flow through the combustion zone.



STARJET

MORE STARJET FEATURES

Maximum Mounting Flexibility provided by 45° air inlet. Four air inlet orientations and wide range of burner/blower mounting arrangements available.

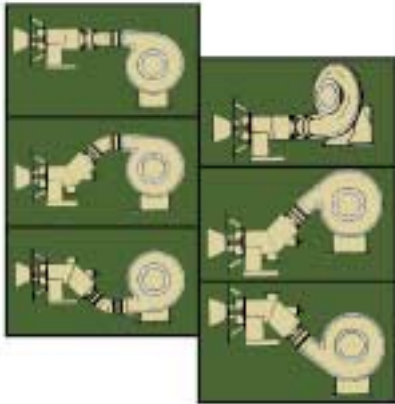

Stainless Steel Ignition Cone eliminates heavy refractory ignition tile. The cone lasts considerably longer and is less expensive to replace.

Direct Drive Blowers are available at 24 and 36 osig. The higher pressure 36 osig blowers, highly desirable for burning heavy fuel oil, are necessary for operation at higher elevations and to achieve high combustion intensities in the dryer.



Flame Shape Adjustment is achieved by moving the adjustment lever at the side of the burner. This lever is directly linked to the adjustable spin vanes. This feature greatly reduces set up time at initial start-up or whenever the plant is relocated, and permits fine-tuning when mix changes require. Fine-tuning can be accomplished in minutes instead of hours.



Dual Scanner Tubes permit monitoring pilot and main flames individually. The scanner tubes are connected to an air purge, which minimizes dirt infiltration and provides cooling air.



Fuel Flow Meter is standard on both oil and LP fuel manifolds.



Oil Atomizer requires only low pressure air. No need for high pressure air compressor.



Oil or LP Nozzle Removable from rear of burner for easy-access maintenance.



Miniskid permits the burner to be mounted with the air inlet at any of four positions.



STARJET

STARJET CAPACITIES

24 osig Direct Drive Blowers

BURNER MODEL	AIR FLOW (scfm)	PRESSURE (osig)	TBA BLOWER MODEL	MOTOR HP	CIMA FAN RATING (acfm @ 350 °F)	MAX CAPACITY (BTU/hr)
SJ075	983	24	TBA-24-10	10	7,000	12.1 x 10 ⁶
SJ150	1,496	24	TBA-24-15	15	13,000	22.7 x 10 ⁶
SJ200	2,350	24	TBA-24-20	20	21,000	37.0 x 10 ⁶
SJ260	2,870	24	TBA-24-25	25	26,000	45.1 x 10 ⁶
SJ360	4,350	24	TBA-24-50X	40	40,000	70.4 x 10 ⁶
SJ520	6,000	24	TBA-24-50	50	53,000	93.3 x 10 ⁶

36 osig Direct Drive Blowers

BURNER MODEL	AIR FLOW (scfm)	PRESSURE (osig)	TBA BLOWER MODEL	MOTOR HP	CIMA FAN RATING (acfm @ 350 °F)	MAX CAPACITY (BTU/hr)
SJ075	1,200	36	TBA-36-20	20	8,600	15.2 x 10 ⁶
SJ150	1,832	36	TBA-36-25	25	16,000	27.9 x 10 ⁶
SJ200	2,800	37	TBA-36-40	40	23,000	40.5 x 10 ⁶
SJ260	3,500	36	TBA-36-50	50	28,000	49.3 x 10 ⁶
SJ360	5,400	37	TBA-36-75	75	43,000	75.6 x 10 ⁶
SJ520	7,300	36	TBA-36-100	100	55,000	96.8 x 10 ⁶
SJ580	7,900	36	TBA-36-100	100	68,000	120 x 10 ⁶
SJ750	9,940	38	TBA-36-125	125	85,000	150 x 10 ⁶
SJ980	12,200	36	TBA-36-150	150	128,000	200 x 10 ⁶

Note: Only 40% of air for combustion is passed through the burner. The remaining 60% of air for combustion plus a minimum of 35% excess air must be induced by the dryer exhaust system at a negative -0.25" wc pressure at the burner/breeching ring. Dryer leakage air is not useable in the combustion process.

NFPA FUEL MANIFOLDS

Hauk fuel manifolds conform to the safety standards of the National Fire Protection Association (NFPA) as established in their publications.

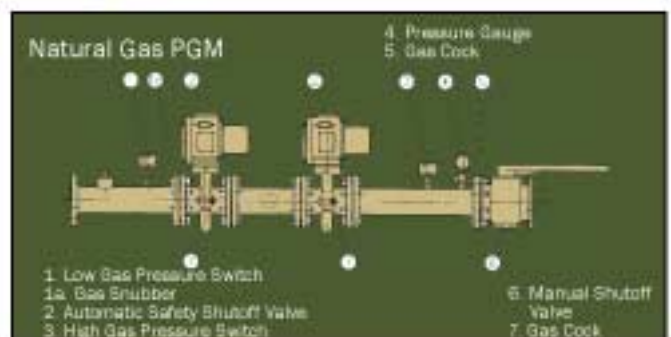
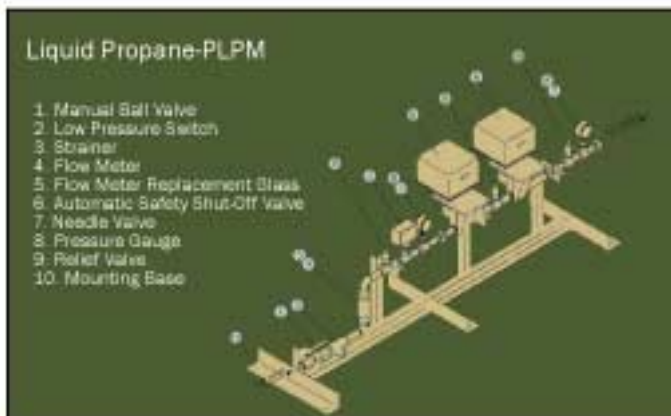
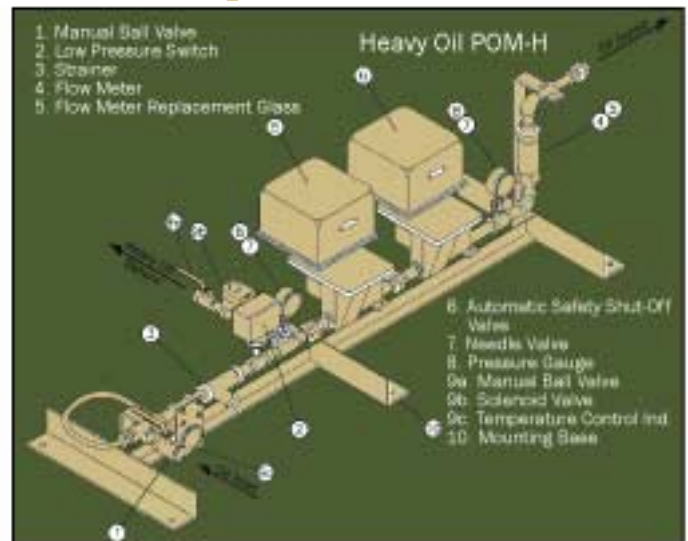

STARJET

TYPICAL PIPING SCHEMATIC

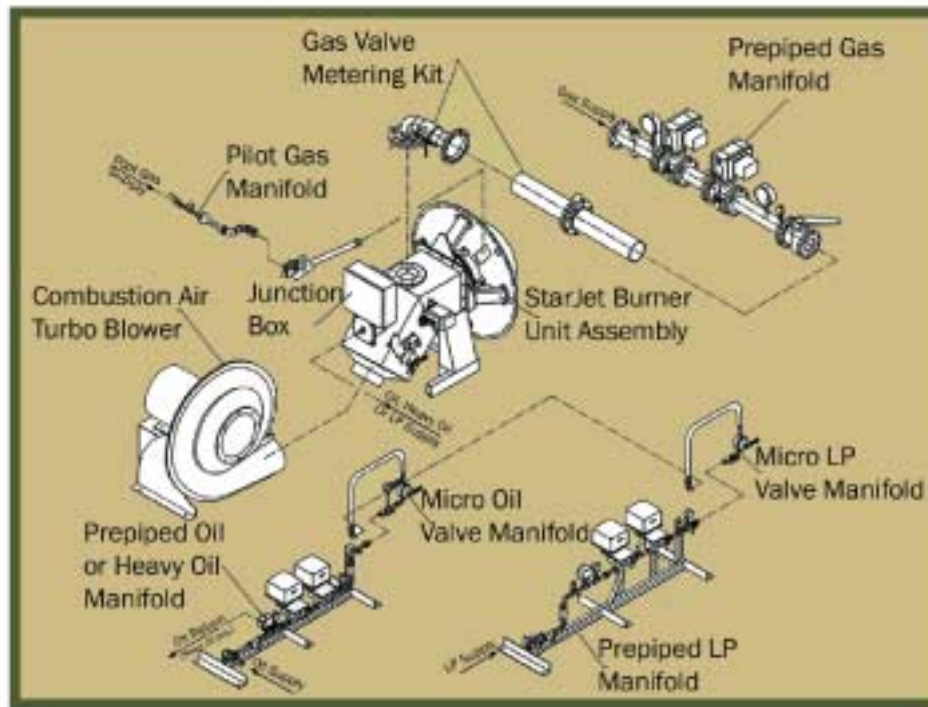

ORDERING INFORMATION

TO ORDER:

BURNER UNIT, SJ O - 4200 X - XXX - XX - 06-X - 00, STARJET OIL

STARJET

FUEL

O—Oil
G—Natural Gas
L—LP
O/G—Oil/Natural Gas
G/L—Gas/LP

SERIES

4 = 4000 Series—Open Fired

BURNER SIZE

75	520
150	580
200	750
260	980
360	

PRODUCTION MODEL

MINI SKID

1—Standard
2—Special

CONTROL MOTOR

1—Medium Torque
2—High Torque

SPECIAL OPTIONS

00—None
10—50 HZ—Consult Hauck for other special options

HEAT SHIELD

1—Single
2—Dual

AIR INLET POSITION

03—3 o'clock
06—6 o'clock
09—9 o'clock
12—12 o'clock

JUNCTION BOX

3G—Wired for BCS 3000G
3H—Wired for BCS 3000H
3J—Wired for BCS 3000J
5A—Wired for BCS 5000A
5B—Wired for BCS 5000B
99—Wired for Special Panel

FUEL MANIFOLDS

1—Standard
2—Special

*Gas Manifold Specified Separately



HAUCK MANUFACTURING COMPANY
P.O. BOX 90
LEBANON, PA 17042
PHONE: 717-272-3051
FAX: 717-273-9882

SJ(A)-1